



LESLIE
CONTROLS, INC.

A division of CIRCOR International, Inc.
12501 Telecom Drive, Tampa FL 33637

**INSTALLATION, OPERATING,
AND MAINTENANCE INSTRUCTIONS
DIAGRAMS & PARTS LIST**

26/2.5.1
Rev. 3

PMC-1 ELECTRO-PNEUMATIC CONTROLLER

TABLE OF CONTENTS

Specifications2
Introduction4
Operation4
Installation4
Pneumatic Connections4
Field Wiring4
Start-Up5
Troubleshooting6

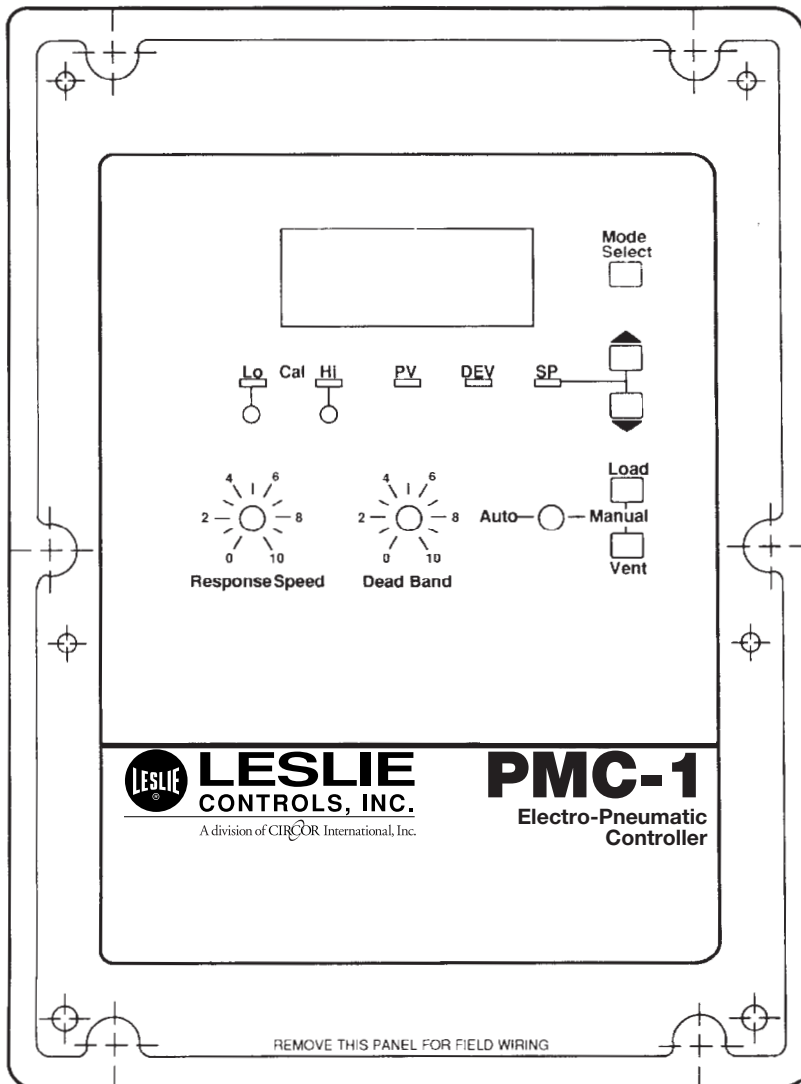

SPECIFICATIONS

SUPPLY VOLTAGE:	115 VOLTS 50/60 HZ 230 VOLTS 50/60 HZ 24V DC
OPERATING VOLTAGE RANGE:	90 TO 110% OF RATED VOLTAGE
POWER CONSUMPTION:	10 WATTS (MAX.), .7W STEADY STATE
INPUT:	4 - 20 mA (STD), PROTECTED AGAINST ACCIDENTAL 24V INPUT TO THE CURRENT INPUT TERMINALS RTD (OPTIONAL)
OUTPUT:	4-20 mA(STD), ACCURACY $\pm 5\%$ SPAN; MAX LOAD = 350 Ω
CONTROL ACTION:	DIRECT OR REVERSE (SWITCH SELECTABLE)
LOCAL SET POINT ADJUSTMENT:	PUSH BUTTON SWITCHES AND DIGITAL DISPLAY
REMOTE SET POINT ADJUSTMENT:	4 - 20mA STANDARD INPUT, DEFAULTS ON LOSS OF SIGNAL
DISPLAY MODES:	CALIBRATION (HIGH/LOW), SET POINT, PROCESS VALUE, DEVIATION
AIR SUPPLY:	100 PSI MAX., 40 MICRON FILTERED
OUTPUT:	0 TO MAXIMUM SUPPLY PRESSURE
AIR CONSUMPTION:	NO AIR CONSUMPTION AT STEADY STATE
DISPLAY:	3-1/2 DIGIT LCD BACKLIT DISPLAY (GREEN BACKGROUND)
ACCURACY:	$\pm 0.5\%$ OF FULL SPAN
SETTING ACCURACY:	ACTUAL SET VALUE COINCIDES WITH INDICATED SET VALUE
RESPONSE SPEED RANGE:	200:1
AMPLIFIER GAIN (SLOW LOOP):	NORMAL= 6(MAX); HIGH = 12(MAX)
DEAD BAND:	ADJUSTABLE FROM $\pm 0\%$ TO 5% OF FULL SPAN
INPUT RESISTANCE TO CURRENT LOOP:	100 OHMS X CURRENT + 0.7 VOLTS
AMBIENT TEMPERATURE:	-4°F TO 140°F (-20° TO 60°C) (HEATERS FOR -40°F OPTIONAL)
WEIGHT:	8 LBS. (3.6KG)
OVERALL DIMENSIONS (INCLUDING MOUNTING BRACKET):	9.75" WIDE X 13.5" HIGH X 6.3" DEEP (25CM X 34CM X 17CM)
ENCLOSURE APPROVAL	NEMA 1-2-3-3S-4-4X-12-13.
ENCLOSURE MATERIALS:	ENCLOSURE: NORYL HINGED COVER: POLYCARBONATE
PNEUMATIC FITTINGS:	1/8 NPT (FEMALE)
AIR DELIVERY:	SOLENOID FULLY OPEN: 0.76 SCFM AT 30 PSI 1.23 SCFM AT 60 PSI 1.71 SCFM AT 90 PSI
AUTO/MANUAL:	ALLOWS MANUAL OPERATION OF SOLENOID VALVES TO LOAD OR VENT THE ACTUATOR

PMC CONTROLLER MOUNTING DIMENSIONS

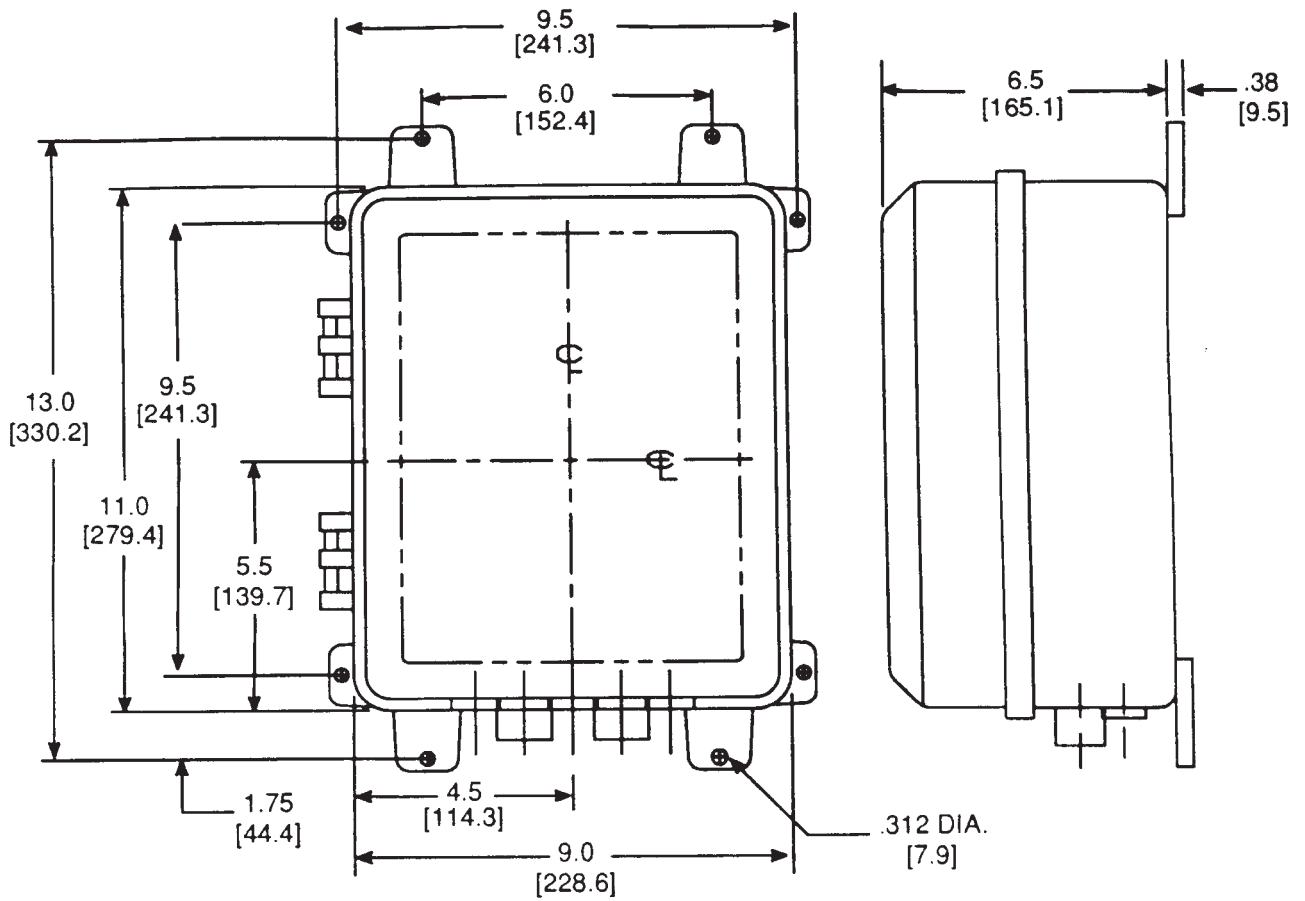

INCHES
[MM]

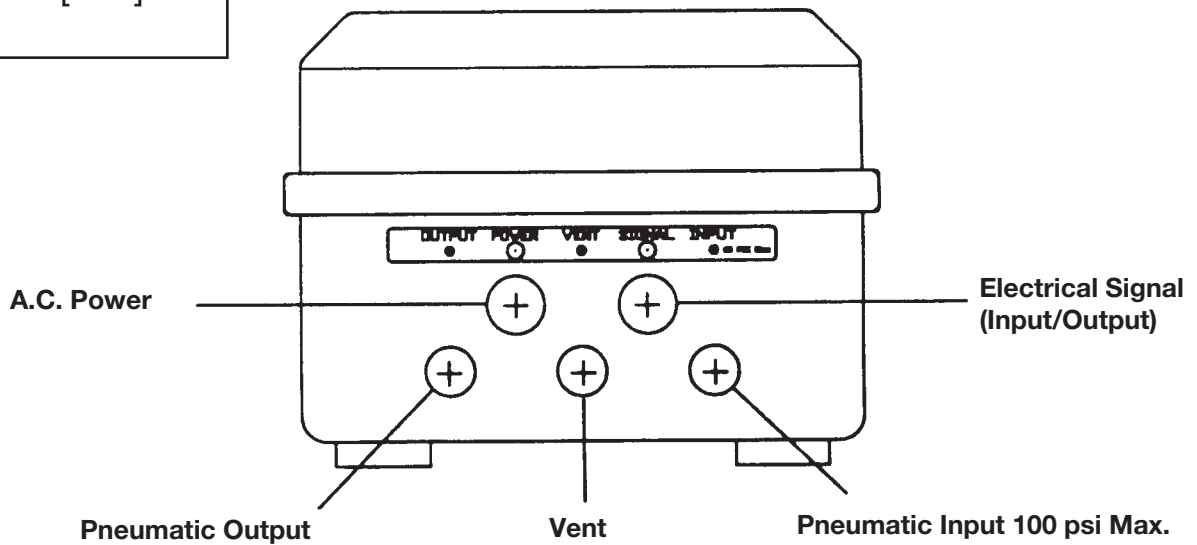

FIGURE 1

A. Introduction

The Leslie PMC-1 electro-pneumatic controller can be used to control pressure, temperature, liquid level, and other process variables. It accepts signals from any standard 4-20 mA transmitter and provides a pneumatic output to operate a diaphragm control valve, etc. It provides the following features:

- 1) The controller supplies 24 volt D.C. power for the transmitter, eliminating the need for a separate D.C. power supply.
- 2) It provides high volume air output at pressures up to 100 psig to directly operate a diaphragm control valve. I/P transducers and valve positioners are not required or recommended.
- 3) There are no small air orifices to plug or foul (.060" dia. solenoid ports)
- 4) There is no air consumption except when air is being loaded onto the control valve diaphragm.

B. Operation

The electronic circuit of the controller compares the signal from the transmitter to the desired set point. If the error is greater than the dead band, electrical pulses are sent to one of the two internal air solenoid valves. One valve increases output air pressure and the other bleeds it. Each time a pulse is received, the resulting pressure on the diaphragm of the control valve increases or decreases slightly. If the error is large, the solenoid valves are held open longer to increase the speed of output changes. For small errors, the pulse width is decreased to prevent overshoot. The response speed adjustment can be used to control how quickly the output changes for a given error. Adjusting the dead band will allow the controller to ignore small changes or "noise" in the system. The overall result is a more accurate and stable system.

C. Installation

Mount the controller in a location that will allow access to the internal adjustments. See Figure 1 for mounting dimensions. It should be mounted in a location where the temperature will be between -4°F and 140°F. Temperatures above or below these limits will affect the LCD although the controller would continue to function. A location within 50 ft. of the control valve is recommended to reduce time lags in the pneumatic signal. Where the distance to the control valve is large, an optional external solenoid valve package (PMC-1 local control module model RCS-90) can be used.

WARNING - Electrical power must be supplied through an external circuit breaker or fuse protection. An external switch must be provided to turn off power. Always turn off power before removing the internal field wiring panel.

Pneumatic connections:

Connect air supply and output lines to the 1/8" NPT connections at the bottom of the controller. The center connection is for air exhaust and is supplied with a porous metal filter/silencer which should not be removed.

Corrosion resistant 3/8 in. O.D. tubing or 1/4 in. pipe is recommended for the air lines. Connect air supply to the right hand connection labeled "Input" and output to left hand connection labeled "Output" to actuator. See Figure 1. The supply line should be fitted with a pressure gauge and 50 micron filter/regulator to remove any floating particles. If the supply air is mixed with traces of oil, a filter capable of removing oil should be used. (CAUTION: Some lubricating oils permanently damage solenoid valves.)

WARNING - Turn off electrical power before removing the internal field wiring panel

Field Wiring:

1. After mounting the PMC-1 at the desired location, open the cover by loosening 5 screws and the thumb screw. Then remove the field wiring panel by loosening two captive screws. The terminal block wiring diagram shown in Figure 2 appears on the back of the panel. Power and signal lines should be routed through separate conduits to avoid interference. Transmitter or RTD signal lines should use shielded cable grounded at terminal 2 in insure against RF interference.
2. Connect the transmitter wires as shown in Figure 3 . A two wire transmitter should be powered with the 24v DC supply from the PMC-1 by connecting the positive wire to terminal number 1 and the other transmitter wire to terminal 3 of TB-2. Twisted pair wires can be used for connecting the transmitter to the PMC-1. If a shielded pair of wires is used, connect the shield to terminal 2 of TB-2. Jumper at J5/J6 must be on J5. For 4-wire transmitters, see Appendix B.
3. For external set point connection (4-20mA) connect two wires to terminals 5 and 4 of TB-2. Terminal 5 is positive (current flows into terminal 5) and terminal 4 is negative. (See Figure 4)

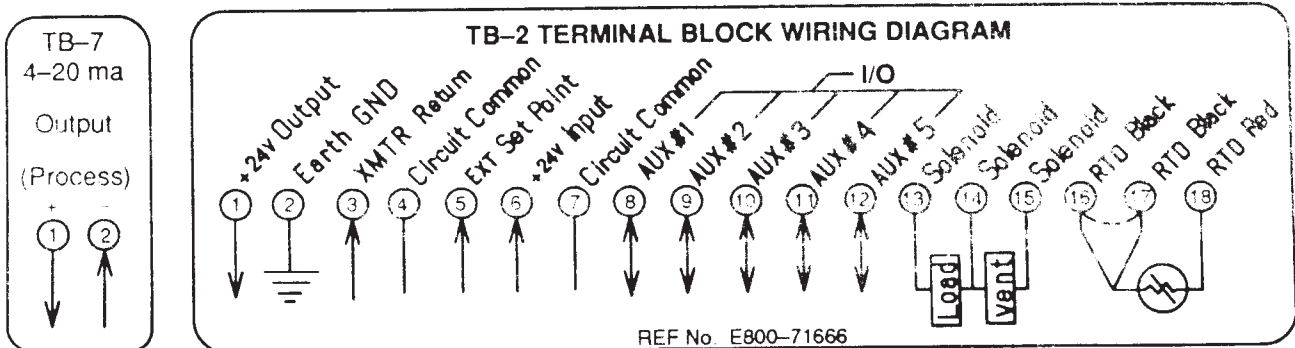

FIGURE 2

4. Terminals 8 through 12 have been reserved for adding future options to the controller.
5. Terminals 13, 14, 15 are used to connect the optional local control module model RCS-90. This module can be used if the PMC-1 is mounted at a remote location from a control valve.
6. When the PMC-1 is being used as a temperature controller with an RTD, an optional signal conditioning card, calibrated for a temperature range suitable for the process, must be installed in TB 5. Jumper at J5/J6 must be on J6. (See figure 7) For a 3 wire RTD, connect the two RTD wires that are internally connected together (zero resistance between them) to terminals 16 and 17 and the remaining connection to terminal 18 of TB-2. (See Figure 5). For a 2 wire RTD, jump terminals 16 and 17. (See Figure 6). See Appendix C for guidelines on practical distance limitations.
7. Power and signal lines should be routed through separate conduits to avoid interference. Set the 115/230 voltage switch (SW1) to match the supply voltage. **DO NOT TURN ON A.C. POWER YET.** With AC power circuit breaker OFF, connect power leads (unpowered) to TB-1 (Figure 7). Connect the black wire (HI) to terminal 1, the white wire (LO) to terminal 2 and the green or green/yellow earth ground wire to terminal 3 of TB-1. If the PMC-1 is powered by 24v DC, connect the positive connection to terminal 6 and the negative connection to terminal 7 of TB-2, and DO NOT connect any wires to TB-1. (See Figure 8).
8. For 4-20mA output, connect recorder, alarms or other auxiliary device to TB-7 noting the polarity. NOTE: The 4-20mA output will be within $\pm 0.5\%$ (of span) of the value indicated on the PMC-1. Re-calibrate the remote device to agree with the PMC-1, do not re-calibrate the PMC-1.

D. Start-Up

- 1) Close stop valves upstream and downstream of the diaphragm control valve.

CAUTION - All the pneumatic connections must be tight enough to be leak proof for proper operation. Air connections **MUST** be checked with a soapy water solution and bubble tight.

WARNING - Keep stop valves closed until all adjustments and checks in steps 2 -10 are completed.

WARNING - Turn off electrical power before removing the internal field wiring panel.

- 2) Take off field wiring panel by loosening screws.
- 3) Set the direct/reverse switch (SW3) to the proper position. (See Figure 7). When set on direct, the air output will increase when the signal from the transmitter increases and vice versa.

For example, if the system is being used to control pressure downstream of a normally closed control valve, reverse action would be required (increasing system pressure will increase the signal from the transmitter and this must produce a decrease of output signal air pressure to close the control valve).

- 4) Install the set point selector jumper J16-J21. This jumper allows the PMC-1 to operate in one of two different set point modes, local or remote.

LOC		Local set point
REM/LOC	}	Remote set point with selection of defaults.
REM/LPOS		
REM/VENT		
REM/LOAD		
REM/ZERO		

Installing jumper in 'LOC' (local) position allows set point adjustments using the up or down push buttons located on the front panel, only when the "SP" LED is lit. By inserting the jumper in any of the remaining five positions, the controller accepts a (4-20mA) external set

WIRING DIAGRAMS FOR TYPICAL INSTALLATIONS

Wiring Connections for 4—20 mA Transmitter (e.g. pressure or level)

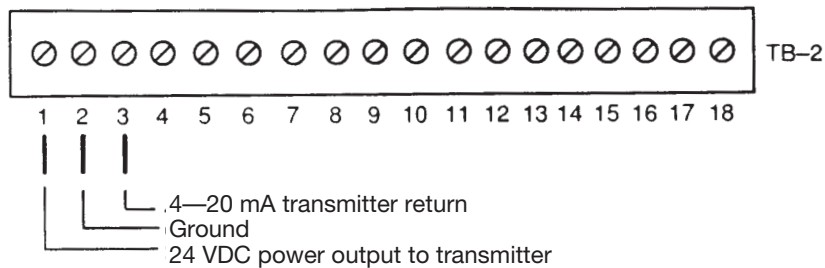

FIGURE 3

NOTE:
Jumper J5/J6 must be on J5

Wiring Connections for External Set Point

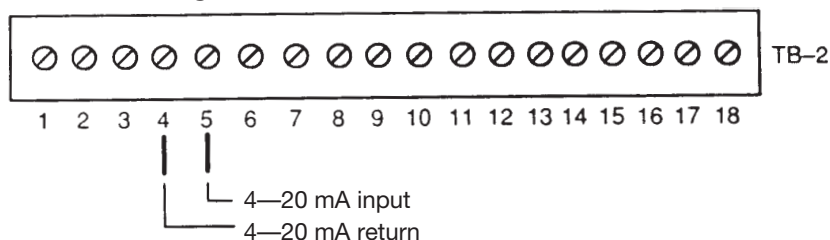

FIGURE 4

point signal with five selectable defaults in case of loss of external set point signal.

- “REM/LOC” Controller will default to Local set point control.
- “REM/LPOS” Default to the last valve position prior to loss of signal.
- “REM/VENT” Vent air from actuator on loss of signal.
- “REM/LOAD” Load air into the actuator on loss of signal.
- “REM/ZERO” Default to “ZERO” set point on loss of signal.

- 5) If the PMC-1 is being used for controlling slow reacting processes like temperature and level, select the control format for slow-acting control loops by moving the process speed switch to the “SLOW” position. (See figure 7). For fast processes (like pressure control) switch the process speed switch to the “FAST” position. For control loops other than pressure, temperature, or level, install the PMC-1 with the control format that will be most suited to the control system’s reaction to control valve change.
- 6) For initial adjustment, turn the response knob to mid position, and dead band to position 0.5.
- 7) Connect the appropriate jumper, as shown in Figure 7 to locate the decimal point for maximum resolution of the display in relation to the input transmitter. (The PMC-1 is shipped with the jumper at J10). The following table shows the range of the display at each jumper position.

J7 = 0.000 to ±1.999
J8 = 00.00 to ±19.99
J9 = 000.0 to ±199.9
J10 = 0000 to ±1999

The LCD display reads the value of the selected mode as indicated by the lit LED.

EXAMPLE: If the PMC-1 controller is being used to control pressure, and the pressure transmitter is calibrated for a range of 0-100 psig, then the maximum resolution will be achieved by placing the decimal point between the third and fourth digits (J9), so that the display will read “100.0” at full scale.

- 8) Replace the field wiring cover and turn on the external electrical power.
- 9) Display calibration using mode selection button.

The display can be calibrated in a range from -1000 to +1999 units. A decimal point can be placed after the second, third or fourth digit. If a change is required, turn off the external power, then see step 7, above.

- a) Press the mode selection button until the “Calibrate LO” LED is lit. Using a small screw driver supplied with the unit adjust the “LO” potentiometer on the front of the panel so that the display indicates the bottom range of the transmitter.
- b) Press the mode selection button until the “Calibrate HI” LED is lit. Adjust the “HI” potentiometer on the front of the panel so that the display indicates the top range of the transmitter.

EXAMPLE ONLY: DO NOT CALIBRATE TO THESE VALUES. If the PMC-1 controller is being used to control temperature, and the RTD with optional circuit card is calibrated for -25 deg. C to +175 deg. C, then the display must be calibrated to read “-25.0” when the “CALIBRATE LO” LED is lit, and “175.0” when the “CALIBRATE HI” LED is lit.

- 10) Using one of the pressure sensitive labels supplied, label the display to indicate the unit of measurement for your process, i.e. pressure, temperature, gpm, etc.
- 11) Adjust the air supply pressure to the controller by adjusting the filter/regulator. The pressure should be set 5 to 10 psig higher than required to operate the diaphragm control valve. Do not exceed 100 psig or the rating of the equipment served, whichever is less.
- 12) Push the mode select button until the “SP” LED lights up. Using the up/down buttons, adjust LCD display observing operation of the diaphragm control valve. If it does not move in the proper direction use the direct/reverse switch (SW3) to obtain desired operation of the valve.
- 13) Adjust the set point to move the control valve to the closed position.
- 14) The system can now be started.

WARNING - This instruction can not cover the safety precautions and procedures required for safe start-up of every system. Make sure you understand the system and its safe operation before start-up.

- 15) For bumpless transfer, move the auto/manual switch to the manual position. Select the “SP” (set point) mode and adjust to desired set point. Select the “PV” (process value) mode. Using the load or vent buttons, adjust the system until the display agrees with the set point. Move the auto/manual switch to the auto position for continued automatic control.
- 16) Adjust response speed and dead band to provide stable control. Maximum speed and minimum dead band will provide the highest accuracy but the system may cycle. It’s best to adjust the response speed and dead band at minimum and maximum system flows.

Initial Tuning

- 17) Adjust response speed and dead band as follows:

<u>Temperature or level control</u>	Speed of response	3.0
	Dead band	.5

If temperature or level cycles, reduce speed of response. If no cycling is occurring, keep increasing speed or response until cycling begins, then back off half a unit.

<u>Pressure or flow control</u>	Speed of response	6.0
	Dead band	.5

If pressure or flow cycles, reduce speed of response. If no cycling is occurring, keep increasing speed of response until cycling occurs, then back off half a unit.

The ideal tuning of the PMC-1 would be the maximum speed of response and minimum dead band setting you can use without the system going into constant oscillation after an upset.

E. Troubleshooting—General

- 1) System cycles
 - a) Make sure Pneumatic connections from PMC-1 to the valve are leak free. (Check with soapy water)
 - b) Adjust dead band and response speed. (See step 17 of start-up instructions).
 - c) Check that the diaphragm control valve is operating within its rated flow rangeability (usually 10-90% open) and valve stem doesn’t stick.

CONNECTING AN RTD TO THE PMC

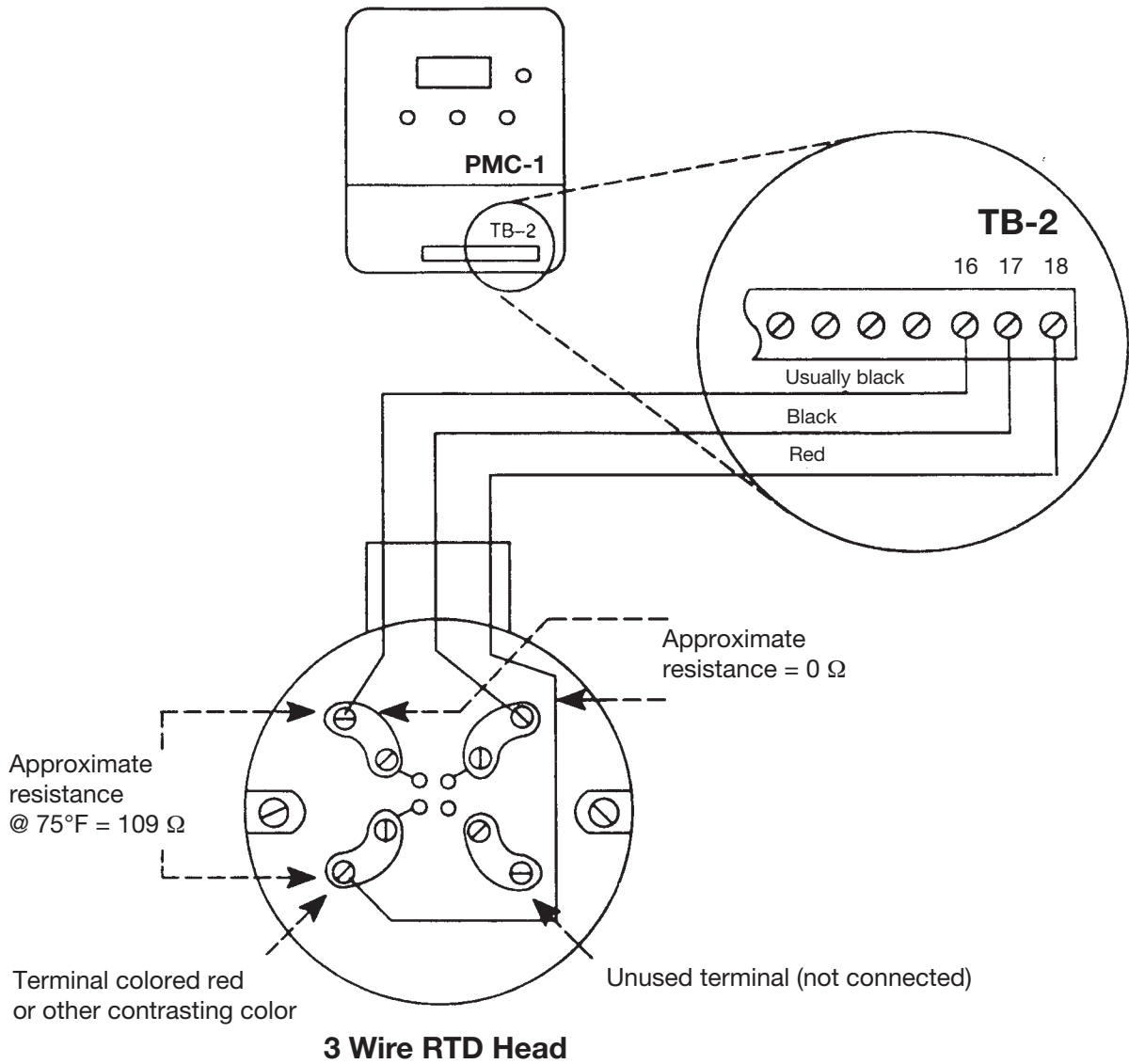

FIGURE 5

Wiring Connections for Two—Wire RTD (temperature)

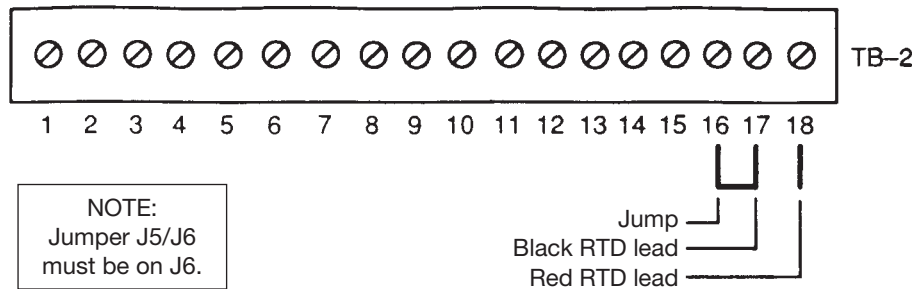

FIGURE 6

- 2) Control valve operates in the opposite direction required to satisfy the system .
 - a) Check position of direct/reverse switch.
- 3) Controller does not operate at all (LCD display off).
 - a) Check A.C. power connection.
 - b) Check fuse (F1 in Figure 2).
 - c) PMC-1 operates but no display, replace LCD display.
- 4) Controller does not respond to changes in local set point adjustment.
 - a) Check that the set point jumper is in the local position.
- 5) Controller does not respond to changes in the controlled variable.
 - a) Check connections and signal from transmitter.
 - b) Re-check LO-HI calibration and set point.
- 6) The displayed process value does not match the actual when measured against thermometer or pressure gauge.
 - a) Check display calibration (step 9 of start-up instructions).
 - b) Check calibration of transmitter. (See instructions supplied with transmitter).
 - c) Remember, the accuracy of the PMC-1 is $\pm 0.5\%$ of span (much better than most gauges or thermometers). For example, if calibration was from 32-212°F, the span is 180° so the indicated temperature of the PMC-1 would be within $(.005 \times 180) .9^\circ\text{F}$ of actual.
- 7) Control valve does not respond to controller output.
 - a) Check filter/regulator supplying air to controller to make sure that the output pressure is 5-10 psig higher than the pressure required to fully stroke the valve.
 - b) Check actuator operation.
- 8) Process never quite makes the set point.
 - a) Check pneumatic connections for leaks.
- 5) Leaks in pneumatic lines
 - a) Small pneumatic line leaks can cause control instability, particularly when using the PMC-1 with a regulator. Use a soap solution or “snoop” to locate possible leaks.
- 6) Too much air pressure to PMC-1
 - a) If too much air pressure is supplied to the PMC-1, it can overload the actuator or regulator diaphragm causing overshoot and slow response when venting is required.
- 7) Inaccurate calibration
 - a) If the process temperature indicated by the PMC-1 is significantly different from the temperature indicated by a thermometer, check to make sure that the PMC-1 is calibrated according to the range of the signal conditioning card installed (if using an RTD) or the range of the temperature transmitter (if using a thermocouple).
- 8) Trapping problems
 - a) A steam trap that is under sized or malfunctioning can cause the heat exchanger to flood during high load conditions, giving rise to wide swings in process temperature. Check for this problem by manually bypassing the trap under full load conditions, and observe whether there is an improvement in temperature control.
- 9) Incorrect Installation of Regulator
 - a) A poorly installed regulator can cause cycling. Make sure that the regulator is installed in the proper orientation and that the sensing line is installed to provide proper condensate drainage, as indicated in the regulator’s Installation and Operation Manual.
- 10) Poor performance or malfunction of control valve
 - a) A malfunctioning control valve component, such as a leaking or broken actuator stem seal, can cause the system to work poorly or not at all. Also, if an existing control valve from another manufacturer has been used in the system, check for hysteresis, ability to throttle properly, and sizing (over or under).

For Temperature Control Systems

- 1) RTD connection to PMC-1
 - a) If an RTD is being used, make sure that the wires are connected according to the diagram in the PMC-1 Installation and Operation Manual. If in doubt, measure the resistance across the terminals, as shown in Figure 5.
- 2) RTD installation in piping
 - a) If the process temperature indicated by the PMC-1 (a function of the RTD signal) lags considerably behind a thermometer installed in the process line, check to make sure that the RTD is installed directly into the flow path of the process fluid. Unless absolutely necessary, the RTD should not be inside a thermowell. If the above steps have been taken and the lag is still too great, thermocouple with transmitter may be necessary.
- 3) RF interference
 - a) For best protection from radio frequency interference. make sure that the temperature sensing element is connected to the PMC-1 using shielded cable that the shielding is connected to the earth ground.
- 4) Insufficient air pressure to PMC-1
 - a) Make sure that the air pressure supplied to the PMC-1 is sufficient to fully stroke the control valve or to

10 Most Common Problems

- 1) Leaky air connections - must be tested bubble tight with soapy water solution.
- 2) Incorrect field wiring. Re-check connections in reverse order of how they were connected.
- 3) Loose connections.
- 4) Incorrect calibration.
- 5) Speed of response and dead band adjustment.
- 6) Insufficient air pressure supply.
- 7) LCD decimal selector in wrong position.
- 8) Oversized or malfunctioning control valve/regulator.
- 9) Poor condensate drainage from heat exchangers.
- 10) Wrong supply voltage.

CAUTION

Improper installation or maintenance of this equipment can cause damage or personal injury.

1. When installing new equipment, check that it is suitable for the fluid, pressures and temperatures in your system.
2. Make sure that all pressure has been vented from the system before loosening or disassembling any part of the piping system or valve.
3. Before pressurizing the system, make sure that all bolts and gasket joints are tight.

4. When starting up the system, open inlet and outlet stop valves slowly to prevent fluid hammer and thermal shock.
5. Use genuine Leslie replacement parts. Other parts may look the same but may have lower strength or temperature limits.

If you have any questions about the installation, repair or operation of your Leslie equipment, please call Leslie Controls or your local representative.

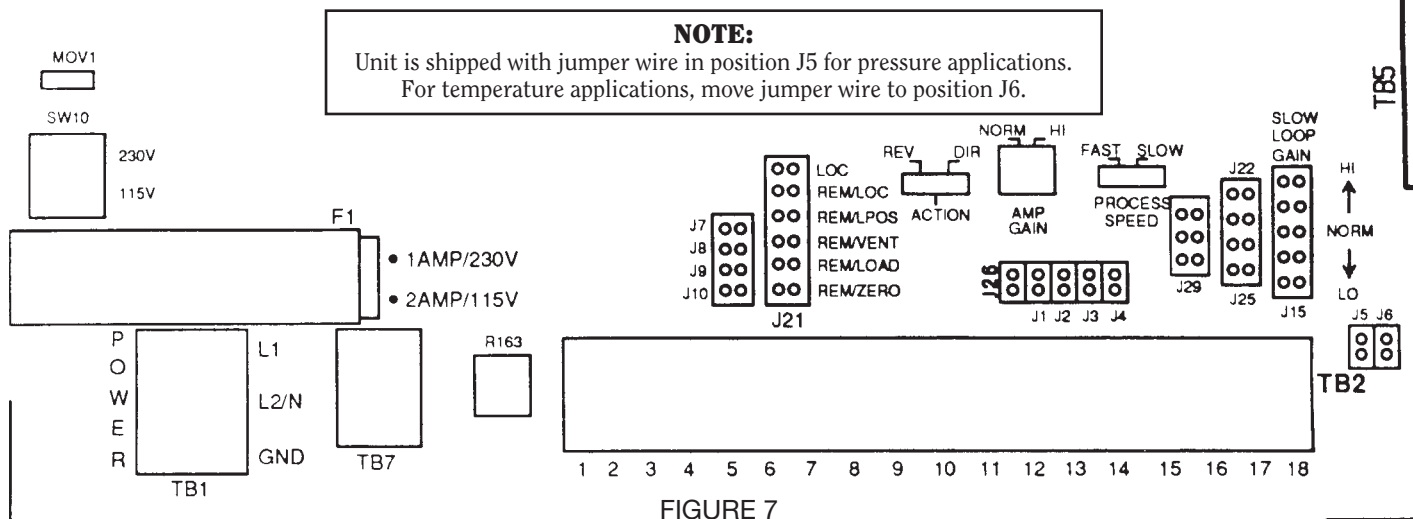

FIGURE 7

- | | |
|---|--|
| <p>J1 CONNECTS "EXT SET" POINT VOLTAGE (0.4 TO 2 VOLTS) TO TB-2 TERMINAL 8 (MARKED AUX# ON PC BOARD)</p> <p>J2 CONNECTS "PV" VOLTAGE (0.4 TO 2 VOLTS) TO TB-2 TERMINAL 9 (MARKED AUX #2 ON PC BOARD)</p> <p>J3 CONNECTS "DEV" VOLTAGE (0±4 VOLTS) TO TB-2 TERMINAL 10 (MARKED AUX #3 ON PC BOARD). THIS IS HIGH IMPEDANCE OUTPUT.</p> <p>J4 CONNECTS 24V INTERNAL POWER TO SOLENOID. IF SOLENOIDS ARE POWERED EXTERNALLY BY EXTERNAL POWER SUPPLY (WHEN SOLENOIDS ARE DIFFERENT FROM STANDARD) J4 MUST BE REMOVED AND EXTERNAL POWER CAN BE BROUGHT TO THE SOLENOIDS AT TB-2 PIN 14.</p> <p>J5 JUMP WHEN EXTERNAL 4-20MA PROCESS FEEDBACK TRANSMITTER IS USED
-OR-</p> <p>J6 JUMP WHEN RTD SIGNAL CONDITIONAL CARD IS INSTALLED IN THE PMC-1.</p> <p>J7 DECIMAL POINT SELECT, REFER TO SECTION D, PARA. 7.</p> <p>J8 DECIMAL POINT SELECT, REFER TO SECTION D, PARA. 7.</p> <p>J9 DECIMAL POINT SELECT, REFER TO SECTION D, PARA. 7.</p> <p>J10 DECIMAL POINT SELECT, REFER TO SECTION D, PARA. 7.</p> <p>J11 SLOW LOOP GAIN ADJUSTMENT (DERIVATIVE GAIN ADJUSTMENT). J13 IS DEFAULT.</p> <p>J12 SLOW LOOP GAIN ADJUSTMENT (DERIVATIVE GAIN ADJUSTMENT). J13 IS DEFAULT.</p> <p>J13 SLOW LOOP GAIN ADJUSTMENT (DERIVATIVE GAIN ADJUSTMENT). J13 IS DEFAULT.</p> <p>J14 SLOW LOOP GAIN ADJUSTMENT (DERIVATIVE GAIN ADJUSTMENT). J13 IS DEFAULT.</p> | <p>J15 SLOW LOOP GAIN ADJUSTMENT (DERIVATIVE GAIN ADJUSTMENT). J13 IS DEFAULT.</p> <p>J16 SET POINT DEFAULT CONDITION SELECTOR, REFER TO SECT. D, PARA. 4.</p> <p>J17 SET POINT DEFAULT CONDITION SELECTOR, REFER TO SECT. D, PARA. 4.</p> <p>J18 SET POINT DEFAULT CONDITION SELECTOR, REFER TO SECT. D, PARA. 4.</p> <p>J19 SET POINT DEFAULT CONDITION SELECTOR, REFER TO SECT. D, PARA. 4.</p> <p>J20 SET POINT DEFAULT CONDITION SELECTOR, REFER TO SECT. D, PARA. 4.</p> <p>J21 SET POINT DEFAULT CONDITION SELECTOR, REFER TO SECT. D, PARA. 4.</p> <p>J22 CONNECTS EXTERNAL SIGNAL FROM TB-2 PIN8 (AUX 1) TO STEERING CIRCUIT IF USED, J1 JUMPER MUST BE REMOVED.
-OR-</p> <p>J23 CONNECTS INTERNAL PROCESS SPEED CONTROL CIRCUIT, TO STEERING CIRCUIT</p> <p>J24 CONNECTS DERIVATIVE CIRCUIT OUTPUT SIGNAL TO TB-2 PIN9 (AUX 2). IF USED, REMOVE JUMPER J2.
-OR-</p> <p>J25 DO NOT USE (STRICTLY FOR FACTORY USE).</p> <p>J26 CONNECTS CIRCUIT COMMON TO TB-2 PIN7.</p> <p>J27 INACTIVE. CONNECTS TO AN OPTIONAL BOARD, IF INSTALLED.</p> <p>J28 INACTIVE. CONNECTS TO AN OPTIONAL BOARD, IF INSTALLED.</p> <p>J29 INACTIVE. CONNECTS TO AN OPTIONAL BOARD, IF INSTALLED.</p> |
|---|--|

Wiring Connections for 24VDC Power

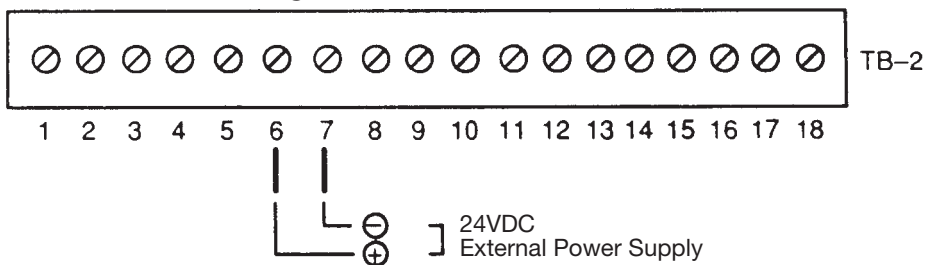
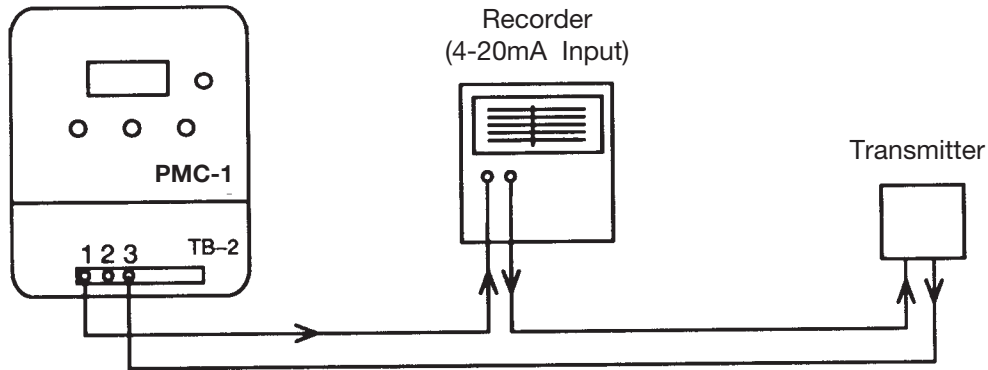

FIGURE 8

APPENDIX A

WIRING MULTIPLE DEVICES IN SERIES WITH THE PMC-1



The PMC-1 is provided with a 4-20mA output for recorders, alarms, etc. It may be possible to overload the 4-20mA output, and additional devices need to be powered in series.

The purpose of this Appendix is to provide guidelines for wiring another device, such as a chart recorder, in series with the PMC-1 and a transmitter.

The acceptability of such a practice is based on the following rule: The total voltage drop of all devices in the circuit must be less than the output voltage of the power supply.

The PMC-1's power supply puts out a total of 24 VDC to the transmitter circuit. As stated in the specifications, the input resistance of the PMC's transmitter circuit is 100Ω. Using Ohm's law, the voltage drop at 20mA (.020 Amps) can be calculated as follows:

$$\frac{\text{Voltage (V)}}{\text{Current (I)}} = \text{Resistance (R)}$$

$$\text{Voltage} = \text{Resistance} \times \text{Current}$$

$$\text{Voltage} = 100 \times .020 = 2.0$$

$$\text{Voltage} = 2.7 \text{ Volts}$$

Thus, at 20mA, the voltage drop of the PMC's transmitter loop is 2.7 volts.

EXAMPLE:

The PMC-1 is being used in a level control application. The differential pressure transmitter used to measure the level has a minimum power requirement of 12 volts. A chart recorder with an impedance (resistance) of 450Ω is being considered for use with the level control system. Can the chart recorder be wired in series with the PMC-1 and dp transmitter?

$$\text{Voltage (Chart Recorder)} = 450\Omega \times .020 = 9 \text{ V}$$

$$\text{Total Voltage} = 2.7(\text{PMC-1}) + 12(\text{dp Transmitter}) + 9(\text{Chart Recorder})$$

$$\text{Total voltage} = 23.7 \text{ V}$$

Since the total voltage is less than the 24 volt output of the power supply, the chart recorder can be wired in series with the PMC-1 and dp transmitter.

Note: Long lengths of wire can result in additional resistance in the loop and must be considered when the total voltage drop from all devices in the loop approaches the voltage of the power supply output. When in doubt, consult Leslie for assistance.

APPENDIX B

CONNECTING 2-WIRE AND 4-WIRE TRANSMITTERS TO THE PMC-1

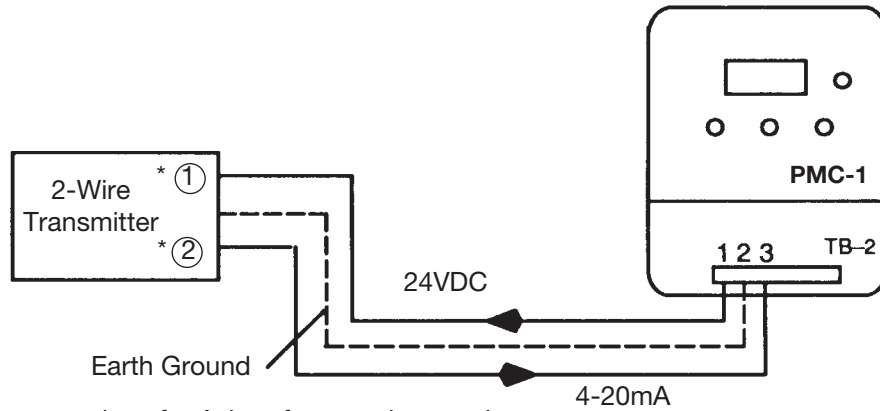

* Terminal connections for Ashcroft transmitters only

Electronic transmitters used to measure pressure, level, and other variables are classified as 2-wire or 4-wire, depending on how they are powered. The PMC-1 can be used with either type of transmitter.

The most common transmitter type is the 2-wire transmitter, which has one power input wire (24VDC nominal) and one

signal output wire (4-20 mA) . In most cases, there is actually a third wire leading from the transmitter, but it is still referred to as 2-wire.

The 2-wire transmitter is connected to the PMC-1 as shown in Figure 8. Terminal 1 supplies 24vDC power to the transmitter, and terminal 3 receives the 4-20mA signal back.

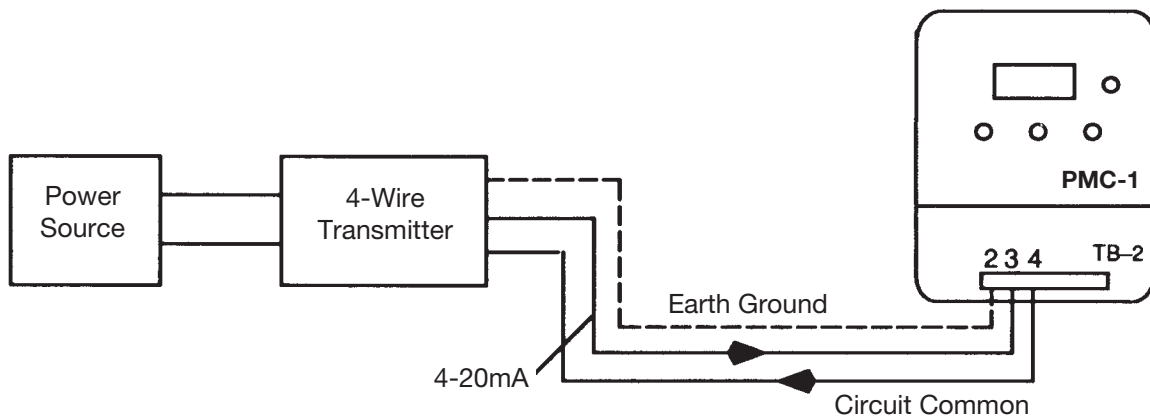

Terminal 2 is an earth ground.

A 4-wire transmitter needs two additional wires, because it receives its power from a separate power source. This type of transmitter can also be used with the PMC-1, and it is connected as shown in Figure 9. Since it receives its power from a separate source, terminal 1, the PMC-1's power is not

used. The 4-20mA signal from the transmitter is connected to terminal 3, as in the case of the 2-wire transmitter, but the circuit is completed by connecting the other wire from the transmitter to terminal 4, circuit common. If the transmitter is equipped with an earth ground, it should be connected to terminal 2.

APPENDIX C

RTD DISTANCE LIMITATIONS WITH THE PMC-1 ELECTRO-PNEUMATIC CONTROLLER

When using the PMC-1 electro-pneumatic controller to control temperature with an RTD and optional built-in signal conditioning card, consideration must be given to the distance of the RTD from the PMC-1 controller.

Since the RTD changes resistance in proportion to temperature change, the signal received by the signal conditioning card installed in the PMC-1 is a variable voltage

signal. The signal conditioning card converts the voltage signal into a 4-20mA signal, which can be used by the PMC-1.

The wire connecting the RTD to the PMC-1 provides additional resistance, which varies according to the gauge and length of the wire. Although the additional resistance of the wire is insignificant over short distances, it can affect accuracy over long distances. The following guideline can be used to insure that any error induced by wire length will be less than 1%.

WIRE GAUGE		MAX. LENGTH FOR 3-WIRE RTD	
AWG	mm ²	Feet	Meters
20	.50	90	27.4
22	.25	55	16.8
24	.22	30	9.1

APPENDIX D

CONTROL OF AIR SIGNAL ON POWER LOSS FOR PMC-1 ELECTRO-PNEUMATIC CONTROLLER

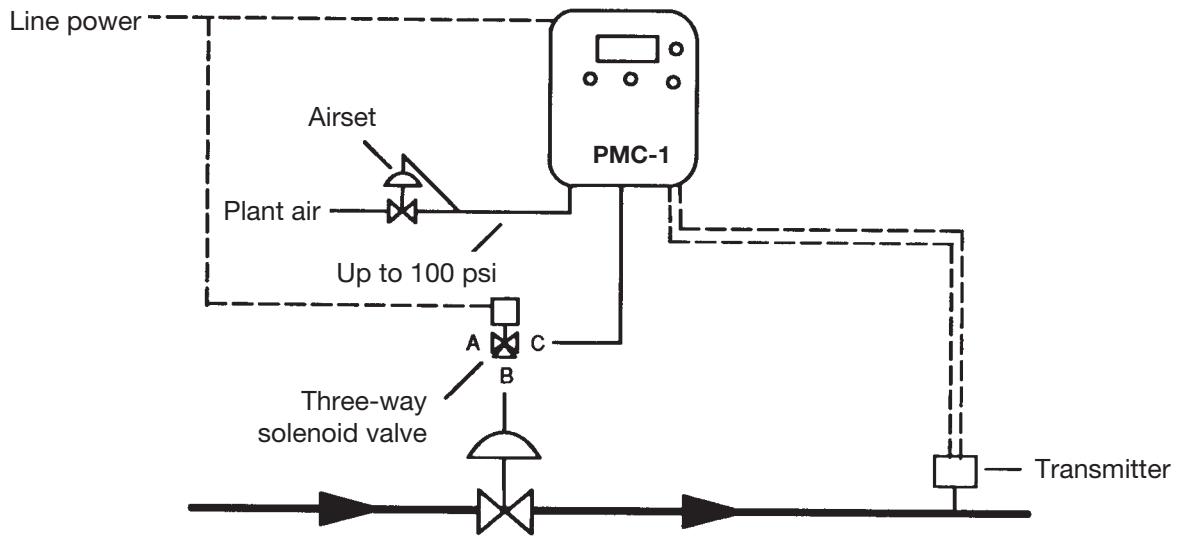

The PMC-1 electro-pneumatic controller modulates a control valve by loading or unloading air to the control valve's pneumatic actuator in a series of pulses. These pulses are controlled inside the PMC-1 by two normally closed solenoid valves.

If the AC power to the PMC-1 should fail for any reason, both internal solenoid valves will remain closed, and the control valve will be locked in its last position. If the avoidance of sudden process changes on power loss is important, this lock-up action is a desirable feature.

In certain situations, however, safety considerations may dictate the use of a normally closed control valve that should shut down the system on loss of power to the controller. In such cases, the arrangement shown above is recommended.

A standard three-way solenoid valve is installed in the air line between the PMC-1 and the control valve. The solenoid is energized from the same power source used by the PMC-1. When the solenoid is energized, ports B and C are connected, and the pneumatic circuit between the PMC-1 and control valve is complete. On loss of power, the solenoid is no longer energized, and ports A and B are connected, allowing the pressure on the actuator diaphragm to vent to atmosphere. If a normally closed actuator has been selected, the control valve will close, and the system will shut down.

A simpler solution, however, is the PMC-1/Vent on Power Failure option which eliminates the need for a separate three-way solenoid valve. Both the venting solenoid and its power source are included in the PMC-1 internally mounted. No extraneous air lines or power sources are needed.

APPENDIX E

TYPICAL TEMPERATURE CONTROL APPLICATION FOR PMC-1 ELECTRO-PNEUMATIC CONTROLLER

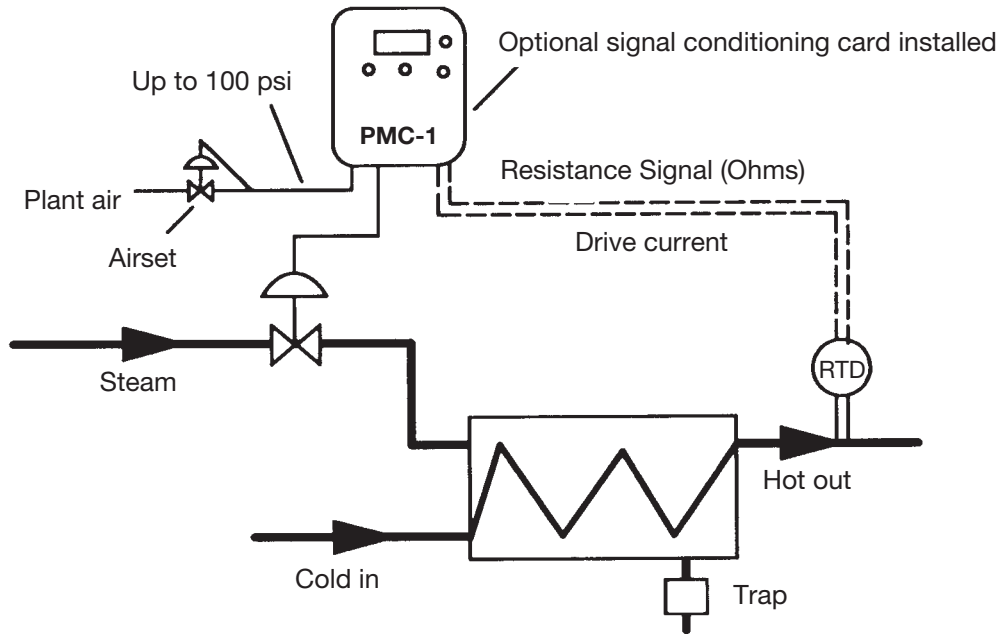

The Leslie PMC-1 electro-pneumatic controller provides an accurate, economical alternative to conventional pneumatic or electronic controllers. A standard RTD (resistance temperature device) is connected to the PMC-1 at the dedicated RTD input terminals. An optional signal conditioning card installed in the PMC-1 converts the resistance signal from the RTD into a 4-20mA signal. The PMC-1 compares the input from the signal conditioning card to the set point, and, using a series of short pneumatic pulses, modulates the control valve as required to maintain

the set point. The PMC-1's "slow loop" control mode can be selected for enhanced control in systems that respond slowly to control valve changes.

During installation, the PMC-1 is calibrated by dialing in the upper and lower limits of the signal conditioning card. The set point and process status can then be read directly from the backlit LCD display. The PMC-1 can be calibrated to display the temperature in either Fahrenheit or Celsius degrees.

APPENDIX F

TYPICAL PRESSURE CONTROL APPLICATION FOR PMC-1 ELECTRO-PNEUMATIC CONTROLLER

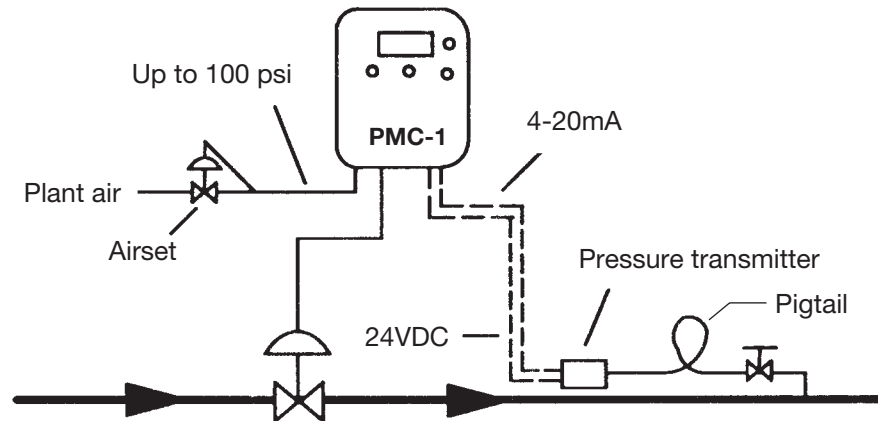

A standard pressure transmitter is connected to the PMC-1 at the transmitter input terminals. The PMC-1 provides 24VDC power to the pressure transmitter, compares the 4-20mA signal returned to the set point and, using a series of short pneumatic pulses, modulates the control valve as required to maintain the desired pressure.

The pressure transmitter is connected to the process pipe by means of a pig tail and isolating valve. The isolating valve provides the ability to change or calibrate the pressure transmitter without otherwise disturbing the system. The pig

tail is important in steam applications to avoid overheating the pressure transmitter. The loop in the pig tail maintains a condensate buffer between the steam and the sensing diaphragm of the pressure transmitter.

During installation, the PMC-1 is calibrated by dialing in the upper and lower limits of the pressure transmitter. The set point and process status can then be read directly from the backlit LCD display in the units of measurement preferred by the user.

APPENDIX G

TYPICAL LEVEL CONTROL APPLICATION FOR PMC-1 ELECTRO-PNEUMATIC CONTROLLER

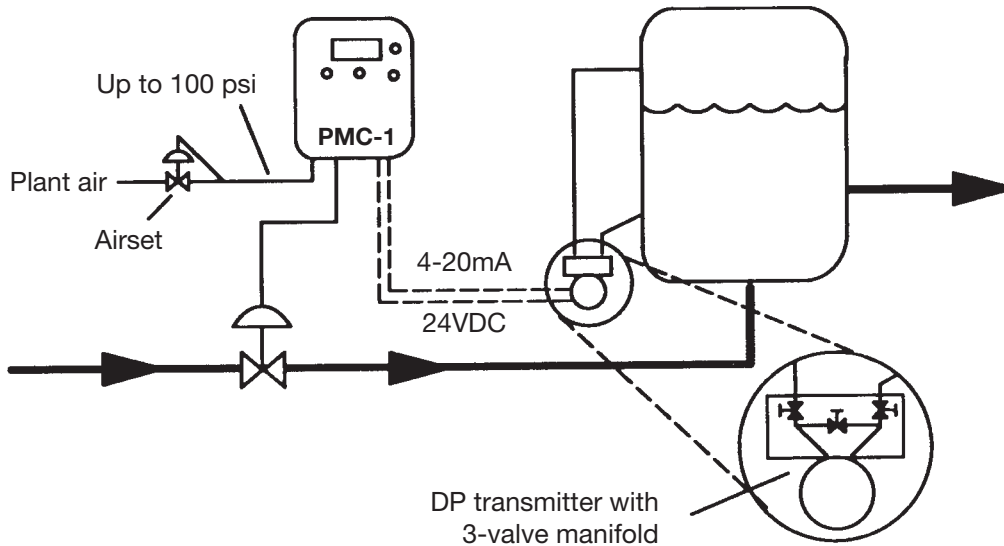

The Leslie PMC-1 electro-pneumatic controller provides an accurate, economical alternative to conventional pneumatic or electronic controllers. A standard differential pressure transmitter is connected to the PMC-1 at the transmitter input terminals. The PMC-1 provides 24VDC power to the dp transmitter, compares the 4-20mA signal returned to the set point and, using a series of short pneumatic pulses, modulates the control valve as required to maintain the desired level. The PMC-1's slow loop control mode can be selected for enhanced control in systems that respond slowly to control valve changes.

In a closed system, the differential pressure transmitter is piped as shown above. The upper sensing line measures the static pressure in the system and acts as a reference point.

the difference between the upper and lower sensing lines is the head pressure of the liquid. In an open system, the reference line is vented to atmosphere. A three-valve manifold is recommended for use with the dp transmitter to facilitate isolation of the transmitter for replacement or in-line calibration.

During installation, the PMC-1 is calibrated by dialing in the upper and lower limits of the differential pressure transmitter. The set point and process status can then be read directly from the backlit LCD display in the units of measurement preferred by the user.

When ordering a dp transmitter for use in a liquid level application, it is important to specify the range (high/low level limits) and the suppression ("WC" in reference line).

**LESLIE
CONTROLS, INC.**

A division of CIRCOR International, Inc.

12501 Telecom Drive, Tampa, FL 33637
Ph: (813) 978-1000 • Fax: (813) 978-0984
www.lesliecontrols.com