

LESLIE
CONTROLS, INC.

**PRODUCT
SPECIFICATION
FORMS**

TABLE OF CONTENTS

DLO(S)-2.....	3
DBO(Y)(S)-3	5
AEROFLOW	7
K-MAX	9
GTW	11
DOT	13
RVK.....	15
2500 SERIES	17
2800 SERIES FIRE-CIDE®	19
ELECTRIC ON / OFF ACTUATORS	20
GENERIC SPECIFICATION FORM.....	21
MODEL QT STEAM CONDITIONING SYSTEM	22
MODEL AT STEAM CONDITIONING SYSTEM	23
MODEL SPID DESUPERHEATER	24

DLO(S)-2 Linear Valve Specification Form

 <p>LESLEIE CONTROLS, INC. <small>A division of CIRCOR International, Inc. 12501 Telecom Drive · Tampa, Florida 33637 (813) 978-1000 · FAX: (813)-978-0984</small></p> <p style="text-align: center; color: red; font-weight: bold; font-size: 1.2em;">CONTROL VALVE SPEC SHEET</p>	Project/Job _____ Unit/Customer _____ P.O./LCO File # _____ Item _____ Contract _____ MFR Serial# _____	Data Sheet _____ of _____ Spec _____ Tag _____ Dwg _____ Service _____
--	--	--

Fluid <input type="checkbox"/> Steam <input type="checkbox"/> Water <input type="checkbox"/> Gas _____ <input type="checkbox"/> Liquid _____	Crit Pres PC _____																																				
Service Conditions Flow <input type="checkbox"/> #/hr <input type="checkbox"/> gpm <input type="checkbox"/> scfh <input type="checkbox"/> _____ Inlet Pressure <input type="checkbox"/> psig <input type="checkbox"/> psia <input type="checkbox"/> _____ Outlet Pressure <input type="checkbox"/> psig <input type="checkbox"/> psia <input type="checkbox"/> _____ Temperature <input type="checkbox"/> °C <input type="checkbox"/> °F _____ Max Press/Temperature: _____ / _____ Density/MW/SG _____ / _____ / _____ Viscosity _____ CP Vapor Pressure <input type="checkbox"/> psia <input type="checkbox"/> _____ Required C _v _____ Noise (dBA) Allowable _____	<table border="1" style="width: 100%; border-collapse: collapse; text-align: center;"> <thead> <tr> <th style="width: 25%;">Max. Flow</th> <th style="width: 25%;">Norm. Flow</th> <th style="width: 25%;">Min. Flow</th> <th style="width: 25%;">Shut-off Pressure</th> </tr> </thead> <tbody> <tr><td> </td><td> </td><td> </td><td> </td></tr> <tr><td> </td><td> </td><td> </td><td> </td></tr> <tr><td> </td><td> </td><td> </td><td> </td></tr> <tr><td> </td><td> </td><td> </td><td> </td></tr> <tr><td> </td><td> </td><td> </td><td> </td></tr> <tr><td> </td><td> </td><td> </td><td> </td></tr> <tr><td> </td><td> </td><td> </td><td> </td></tr> <tr><td> </td><td> </td><td> </td><td> </td></tr> </tbody> </table>	Max. Flow	Norm. Flow	Min. Flow	Shut-off Pressure																																
Max. Flow	Norm. Flow	Min. Flow	Shut-off Pressure																																		

Line Info Pipe Size In _____ /Sch _____ Pipe Size Out _____ /Sch _____

Valve, Body & Bonnet

Body Size in. 1/2 3/4 1 1 1/2 2 2 1/2 3 4

ANSI Class 125 150 250 300 Other _____

Body/Bonnet Material: Cast Iron Cast Steel SST Other _____

End Conn. Inlet/Outlet: NPT SWE BWE Sch. _____ Int. Flanges Other _____

Packing Material: PTFE BTG Laminated Graphite DTFE Other _____

Trim Size

MT 1/4 1/2 3/4 1 1 1/2 2 3 4

MT =% Linear

316SS 316SS / Stellite 316SS / TFE

Actuator

Spring Action: Air to Open Air to Close Last Position Other _____ None

Available Air Supply Pressure: Max. _____ Min. _____

Manual Override: Yes No Type _____

Solenoid Yes No Type _____ Voltage _____

Positioner Yes No Type _____ Pneu E/P

Switch Yes No Type _____ Voltage _____

Air Set Yes No Type: _____ Range: _____

Other Accessories Yes No Type _____

Test ANSI/FCI Leakage Class: IV V VI

DLO ORDER CODE

Class	Material			Valve Size	End Conn.	Actuator	Bonnet Packing	Trim Size	Trim Type	Acces- sories
U	8	5	1	A	1	A	1	D	F	0
1	2	3	4	5	6	7	8	9	10	11

Class - Position 1 U
Material - Position 2, 3 & 4 851 = Iron 853 = Carbon Steel 854 = SST
Valve Size - Position 5 A = ½ B = ¾ C = 1 E = 1½ F = 2 G = 2½ H = 3 J = 4
End Connection - Position 6 1 = Threaded 2 = Flanged 125/150 3 = Flanged 250/300 4 = SWE Sch. 40 (steel only) 5 = BWE Sch. 40 (steel only) 6 = ND16 (steel only) 7 = ND40 8 = SWE Sch. 80 (steel only) 9 = BWE Sch. 80 (steel only) 0 = Other (Specify)

Actuator - Position 7 A = 35 B = 35R C = 35 HOD D = 35R HOD E = 55 F = 55R G ¹ = 55A H ¹ = 55AR I = 55 HOD J = 55R HOD K ¹ = 55A HOD L ¹ = 55AR HOD M = 85 N = 85R P = 85 HOD Q = 85R HOD X = w/o Actuator
Bonnet & Packing - Position 8 1 = Std. Bonnet, BTG 2 = Std. Bonnet, Teflon® V-Ring 3 = Std. Bonnet, LG 4 = Std. Bonnet, Double Teflon®

Trim Size - Position 9 B ² = ¼ D = ½ G = ¾ J = 1 L = 1½ M = 2 N = 2½ P = 3 R = 4
Trim Type - Position 10 B ² = Micro-Taper F = Equal % 316 SS G ³ = Equal % 316 SS/TFE (RES) H = Equal % 316 SS/Stellite J = Linear 316 SS K ³ = Linear 316 SS/TFE (RES) L = Linear 316 SS/Stellite
Number of Accessories - Position 11 1 = 1 accessory 2 = 2 accessories 3 = 3 accessories 4 = 4 accessories 5 = 5 accessories 6 = 6 accessories 7 = 7 accessories 8 = 8 accessories 9 = 9 accessories 0 = 0 accessories

TRIM AVAILABILITY CHART

TRIM DIA	CV ⁴	STROKE	BODY SIZE (IN)							ACTUATOR ¹				
			½	¾	1	1½	2	2½	3	4	35(R)	55 (R)	55A(R)	85(R)
¼MT	0.5	¾	●	●	●	—	—	—	—	—	●	●	—	—
¼	1.5	¾	●	●	●	—	—	—	—	—	●	●	—	—
½	4	¾	●	●	●	—	—	—	—	—	●	●	—	—
¾	9	¾	—	●	●	●	—	—	—	—	●	●	—	—
1	15	¾	—	—	●	*	●	—	—	—	●	●	—	—
1½	30	¾	—	—	—	●	*	●	●	—	●	●	—	—
2	57	1	—	—	—	—	●	*	●	●	—	—	●	●
2½	83	1¼	—	—	—	—	—	●	*	●	—	—	●	●
3	120	1½	—	—	—	—	—	—	—	●	—	—	●	●
4	201	2	—	—	—	—	—	—	—	—	—	—	●	●

1. 55A(R) used on trim sizes 2 through 4 only (Stem Connection 1/2").
2. Microtaper is available in 1/4" Stellite only Code BB.
3. Resilient seat DLOA, DLOAS available with full size trim only.
4. Minimum Cv controllable is Cv from table divided by rangeability.

* Consult factory.

DBO(Y)(S)-3 Linear Valve Specification Form

 <p style="font-size: small;">A division of CIRCOR International, Inc. 12501 Telecom Drive · Tampa, Florida 33637 (813) 978-1000 · FAX: (813)-978-0984</p> <p style="text-align: center; color: red; font-weight: bold; font-size: 1.2em;">CONTROL VALVE SPEC SHEET</p>	Project/Job _____ Unit/Customer _____ P.O./LCO File # _____ Item _____ Contract _____ MFR Serial# _____	Data Sheet _____ of _____ Spec _____ Tag _____ Dwg _____ Service _____
--	--	--

Fluid Steam Water Gas _____ Liquid _____ Crit Pres PC _____

Service Conditions	Max. Flow	Norm. Flow	Min. Flow	Shut-off Pressure
Flow <input type="checkbox"/> #/hr <input type="checkbox"/> gpm <input type="checkbox"/> scfh <input type="checkbox"/> _____				
Inlet Pressure <input type="checkbox"/> psig <input type="checkbox"/> psia <input type="checkbox"/> _____				
Outlet Pressure <input type="checkbox"/> psig <input type="checkbox"/> psia <input type="checkbox"/> _____				
Temperature <input type="checkbox"/> °C <input type="checkbox"/> °F _____				
Max Press/Temperature: _____ / _____				
Density/MW/SG _____ / _____ / _____				
Viscosity _____ CP				
Vapor Pressure <input type="checkbox"/> psia <input type="checkbox"/> _____				

Required C_v _____ Noise (dBA) Allowable _____

Line Info Pipe Size In _____ /Sch _____ Pipe Size Out _____ /Sch _____

Valve, Body & Bonnet

Body Size in. 2 2½ 3 4 6 8

ANSI Class 125 150 250 300 600 Other _____

Body/Bonnet Material: Cast Iron Cast Steel Cr Mo Other _____

End Conn. Inlet/Outlet: NPT SWE BWE Sch. _____ Int. Flanges Other _____

Packing Material: PTFE BTG Laminated Graphite DTFE Other _____

Trim Size 100% 40% Les-Cav Les-sonic Other _____

Actuator

Spring Action: Air to Open Air to Close Last Position Other _____ None

Available Air Supply Pressure: Max. _____ Min. _____

Manual Override: Yes No Type _____

Solenoid Yes No Type _____ Voltage _____

Positioner Yes No Type _____ Pneu E/P

Switch Yes No Type _____ Voltage _____

Air Set Yes No Type: _____ Range: _____

Other Accessories Yes No Type _____

Test ANSI/FCI Leakage Class: III IV V VI

DBO(Y)(S)-3 ORDER CODE

Class	Material			Valve Size	End Conn.	Actuator	Bonnet Packing	Trim Form	Trim Mat'l.	Accessories
U	8	4	1	F	2	A	1	S	J	4
1	2	3	4	5	6	7	8	9	10	11

<p>Class - Position 1 U</p>	<p>Actuator - Position 7 A = 35 B = 35R C = 35 HOD D = 35R HOD E = 55¹ F = 55R¹ G = 55A H = 55AR¹ I = 55 HOD¹ J = 55R HOD¹ K = 55A HOD¹ L = 55AR HOD¹ M = 85/85A² N = 85R/85AR² P = 85/85A HOD² Q = 85R/85AR HOD² R = 135 S = 135R T = 135 HOD U = 135R HOD V = 270 W = 270R X = w/o Actuator Y = 270 HOD Z = 270R HOD</p>	<p>Bonnet & Packing - Position 8 1 = Std. Bonnet, BTG 2 = Std. Bonnet, Teflon® V-Ring 3 = Std. Bonnet, LG 4 = Std. Bonnet, DTFE</p>
<p>Material - Position 2, 3 & 4 841 = Iron 843 = Carbon Steel 845 = Chrome Moly, WC9 XXX = Other</p>	<p>End Connection - Position 6 1 = Threaded 2 = Flanged 125/150 3 = Flanged 250/300 4 = SWE Sch. 40 (Steel & Chrome Moly only) 5 = BWE Sch.40 (Steel & Chrome Moly only) 6 = ND 16 (Steel, Chrome Moly 2"-6" & Iron) 7 = ND 40 Steel ND 10 (Iron only 8") 8 = Flanged 600 Steel 9 = BWE 80 Steel 0 = ND 100 Steel A = RTJ 300 B = RTJ 600 C = SWE Sch. 80 (Steel & Chrome Moly only) D = ND64</p>	<p>Trim Form - Position 9 S = Full Capacity T = Reduced 40% Capacity V = Les-Cav W = Les-Sonic</p>
<p>Valve Size - Position 5 F = 2 G = 2½ H = 3 J = 4 K = 6 L = 8</p>		<p>Trim Material - Position 10 J = Standard 400 SS L = Stellite® Hard Faced P = DBOS, Hi-Temp HF V = TFE Soft Seat</p>
<p>Accessories - Position 11 1 = 1 accessory 2 = 2 accessory 3 = 3 accessory 4 = 4 accessory 5 = 5 accessory 6 = 6 accessory 7 = 7 accessory 8 = 8 accessory 9 = 9 accessory 0 = 0 accessory</p>		

DIGIDBOY: Specify X for Actuator (Position 7) Specify Actuator, Mounting Kit and each option as a separate line item.

1. 55/R used on 2" D(D)BOY(S)-3; 55A/AR used on 2½" - 4" valves.
2. 85A/AR used on 6" D(D)BOY(S)-3; 85/R used on 2½" - 4" valves.

K-MAX Rotary Valve Specification Form

 <p>LESIE CONTROLS, INC. A division of CIRCOR International, Inc. 12501 Telecom Drive · Tampa, Florida 33637 (813) 978-1000 · FAX: (813)-978-0984</p> <p style="text-align: center; color: red; font-weight: bold; font-size: 1.2em;">CONTROL VALVE SPEC SHEET</p>	Project/Job _____ Unit/Customer _____ P.O./LCO File # _____ Item _____ Contract _____ MFR Serial# _____	Data Sheet _____ of _____ Spec _____ Tag _____ Dwg _____ Service _____																																			
Fluid <input type="checkbox"/> Steam <input type="checkbox"/> Water <input type="checkbox"/> Gas _____ <input type="checkbox"/> Liquid _____		Crit Pres PC _____																																			
<p style="color: red; font-weight: bold;">Service Conditions</p> Flow <input type="checkbox"/> #/hr <input type="checkbox"/> gpm <input type="checkbox"/> scfh <input type="checkbox"/> _____ Inlet Pressure <input type="checkbox"/> psig <input type="checkbox"/> psia <input type="checkbox"/> _____ Outlet Pressure <input type="checkbox"/> psig <input type="checkbox"/> psia <input type="checkbox"/> _____ Temperature <input type="checkbox"/> °C <input type="checkbox"/> °F _____ Max Press/Temperature: _____ / _____ Density/MW/SG _____ / _____ / _____ Viscosity _____ CP Vapor Pressure <input type="checkbox"/> psia <input type="checkbox"/> _____ Required C _v _____ Noise (dBA) Allowable _____	<table border="1" style="width: 100%; border-collapse: collapse;"> <thead> <tr> <th style="width: 25%;">Max. Flow</th> <th style="width: 25%;">Norm. Flow</th> <th style="width: 25%;">Min. Flow</th> <th style="width: 25%;">Shut-off Pressure</th> </tr> </thead> <tbody> <tr><td> </td><td> </td><td> </td><td> </td></tr> <tr><td> </td><td> </td><td> </td><td> </td></tr> <tr><td> </td><td> </td><td> </td><td> </td></tr> <tr><td> </td><td> </td><td> </td><td> </td></tr> <tr><td> </td><td> </td><td> </td><td> </td></tr> <tr><td> </td><td> </td><td> </td><td> </td></tr> <tr><td> </td><td> </td><td> </td><td> </td></tr> <tr><td> </td><td> </td><td> </td><td> </td></tr> </tbody> </table>	Max. Flow	Norm. Flow	Min. Flow	Shut-off Pressure																																
Max. Flow	Norm. Flow	Min. Flow	Shut-off Pressure																																		
<p style="color: red; font-weight: bold;">Line Info</p> Pipe Size In _____ /Sch _____ Pipe Size Out _____ /Sch _____																																					
<p style="color: red; font-weight: bold;">Valve, Body & Bonnet</p> Body Size in. <input type="checkbox"/> 1 <input type="checkbox"/> 1½ <input type="checkbox"/> 2 <input type="checkbox"/> 2½ <input type="checkbox"/> 3 <input type="checkbox"/> 4 <input type="checkbox"/> 6 <input type="checkbox"/> 8 ANSI Class <input type="checkbox"/> 150 <input type="checkbox"/> 300 <input type="checkbox"/> 600 <input type="checkbox"/> Other _____ Body/Bonnet Material: <input type="checkbox"/> Cast Iron <input type="checkbox"/> 316SS <input type="checkbox"/> Hast C <input type="checkbox"/> Titanium <input type="checkbox"/> Other _____ End Conn. Inlet/Outlet: <input type="checkbox"/> Wafer <input type="checkbox"/> Sep. Flanges <input type="checkbox"/> Int. Flanges <input type="checkbox"/> Other _____ Packing Material: <input type="checkbox"/> PTFE <input type="checkbox"/> Laminated Graphite <input type="checkbox"/> Teflon Chevron w/Viton O'ring bearing seals <input type="checkbox"/> Other _____																																					
<p style="color: red; font-weight: bold;">Trim Size</p> <input type="checkbox"/> 100% <input type="checkbox"/> 60% <input type="checkbox"/> 40% <input type="checkbox"/> 20% <input type="checkbox"/> Other _____ Flow to: <input type="checkbox"/> Open <input type="checkbox"/> Closed																																					
<p style="color: red; font-weight: bold;">Actuator</p> Spring Action: <input type="checkbox"/> Air to Open <input type="checkbox"/> Air to Close <input type="checkbox"/> Last Position <input type="checkbox"/> Other _____ <input type="checkbox"/> None Available Air Supply Pressure: Max. _____ Min. _____ Orientation: <input type="checkbox"/> Standard <input type="checkbox"/> 90° <input type="checkbox"/> 180° <input type="checkbox"/> 270° Manual Override: <input type="checkbox"/> Yes <input type="checkbox"/> No <input type="checkbox"/> Type _____																																					
<p style="color: red; font-weight: bold;">Solenoid</p> <input type="checkbox"/> Yes <input type="checkbox"/> No <input type="checkbox"/> Type _____ <input type="checkbox"/> Voltage _____																																					
<p style="color: red; font-weight: bold;">Positioner</p> <input type="checkbox"/> Yes <input type="checkbox"/> No <input type="checkbox"/> Type _____ <input type="checkbox"/> Pneu <input type="checkbox"/> E/P																																					
<p style="color: red; font-weight: bold;">Switch</p> <input type="checkbox"/> Yes <input type="checkbox"/> No <input type="checkbox"/> Type _____ <input type="checkbox"/> Voltage _____																																					
<p style="color: red; font-weight: bold;">Air Set</p> <input type="checkbox"/> Yes <input type="checkbox"/> No <input type="checkbox"/> Type: _____ <input type="checkbox"/> Range: _____																																					
<p style="color: red; font-weight: bold;">Other Accessories</p> <input type="checkbox"/> Yes <input type="checkbox"/> No <input type="checkbox"/> Type _____																																					
<p style="color: red; font-weight: bold;">Test</p> ANSI/FCI Leakage Class: <input type="checkbox"/> IV <input type="checkbox"/> V <input type="checkbox"/> VI																																					

K-MAX ORDERING CODE

Class	Material	Valve Size	End Conn.	Valve Rating	Trim Material	Trim Factor	Shutoff Class	Packing	Flow Direction	Actuator	Spring	H.O.D.	Actuator Orientation	# of Accessories	
K	R	C	2	W	1	S	1	4	T	C	B	6	N	2	0
1	2	3	4	5	6	7	8	9	10	11	12	13	14	15	16

Class - Position 1 & 2 KR
Material - Position 3 C = WCB (Carbon Steel) S = CF8M (SST) A = CN7M (Alloy 20) H = CX2MW (Hastelloy C22) T = Grade C-3 (Titanium Grade 3) X = Other
Valve Size - Position 4 0 = 1" 1 = 1½" 2 = 2" 3 = 3" 4 = 4" 6 = 6" 8 = 8" X = Other
End Connection - Position 5 W = Wafer L ² = CS separable flanges S ¹ = SS separable flange F = Integral flanges X = Other

Valve Rating - Position 6 1 = ANSI 150 2 = ANSI 300 3 = ANSI 600 4 = ANSI 150 Special Class 5 = ANSI 300 Special Class 6 = ANSI 600 Special Class X = Other
Trim Material - Position 7 S = Std 316 SS P = Partial Stellite F = Full Stellite A = Alloy 20 ³ H = Hast C ³ T = Titanium R = 316/TFE ⁴ X = Other
Trim Factor - Position 8 1 = Full 6 = 0.6 4 = 0.4 2 = 0.2 X = Other
Shutoff - Position 9 4 = Class IV, Standard 5 = Class V, Optional 6 = Class VI, soft seat only
Packing - Position 10 G = Laminated Graphite T = Teflon-Chevron V = Teflon ⁵ X = Other

Flow Direction - Position 11 O = Flow to Open C = Flow to Close
Actuator - Position 12 A = DR-40-D B = DR-40-R C = DR-55-D D = DR-55-R E = DR-85-D F = DR-85-R N = None/bare stem ⁶
Spring - Position 13 2 = 20 3 = 35 6 = 60 (Standard)
H.O.D. - Position 14 N = None H = Handwheel J = HandJack
Actuator Orientation - Position 15 A = Standard B = 90° C = 180° D = 270°
of Accessories - Position 16 1 = 1 accessory 2 = 2 accessories 3 = 3 accessories 4 = 4 accessories 5 = 5 accessories 6 = 6 accessories 7 = 7 accessories 8 = 8 accessories 9 = 9 accessories 0 = No accessories

NOTE: Consult factory for configurations not listed above.

1. Separable flanges available in 1" - 6", ANSI 150-300 only.
2. Carbon steel separable flanges only good to 800° F service.
3. Optional in 316 & CS valves.
4. Use position 9 Option 6 for shutoff classification. TFE seats 1" - 2" Full Cv only.
5. With Viton O-ring Bearing Seals.
6. Includes Yoke Kit.

GTW Linear 3-Way Valve Specification Form

 <p style="font-size: small;">A division of CIRCOR International, Inc. 12501 Telecom Drive - Tampa, Florida 33637 (813) 978-1000 - FAX: (813)-978-0984</p> <p style="color: red; font-weight: bold; font-size: 1.2em;">CONTROL VALVE SPEC SHEET</p>	Project/Job _____ Unit/Customer _____ P.O./LCO File # _____ Item _____ Contract _____ MFR Serial# _____	Data Sheet _____ of _____ Spec _____ Tag _____ Dwg _____ Service _____
--	--	--

Fluid
 Steam
 Water
 Gas _____
 Liquid _____
 Crit Pres PC _____

Service Conditions	Max. Flow	Norm. Flow	Min. Flow	Shut-off Pressure
Flow <input type="checkbox"/> #/hr <input type="checkbox"/> gpm <input type="checkbox"/> scfh <input type="checkbox"/> _____				
Inlet Pressure <input type="checkbox"/> psig <input type="checkbox"/> psia <input type="checkbox"/> _____				
Outlet Pressure <input type="checkbox"/> psig <input type="checkbox"/> psia <input type="checkbox"/> _____				
Temperature <input type="checkbox"/> °C <input type="checkbox"/> °F _____				
Max Press/Temperature: _____ / _____				
Density/MW/SG _____ / _____ / _____				
Viscosity _____ CP				
Vapor Pressure <input type="checkbox"/> psia <input type="checkbox"/> _____				
Required C _v _____ Noise (dBA) Allowable _____				

Line Info
 Pipe Size In _____ /Sch _____
 Pipe Size Out _____ /Sch _____

Valve, Body & Bonnet
 Body Size in.
 1/2
 3/4
 1
 1 1/2
 2
 2 1/2
 3
 4
 6
 8
 10
 12
 ANSI Class
 125
 150
 250
 300
 Body/Bonnet Material:
 Cast Iron
 Cast Steel
 316SS
 Other _____
 End Conn. Inlet/Outlet:
 NPT
 Int. Flanges
 Other _____
 Packing Material:
 Teflon Chevron
 BTG
 Laminated Graphite

Trim Size
 100%

Flow Path
 Mixing (Converging) (choose one outlet port)
 Diverting (Diverging) (choose two outlet ports)

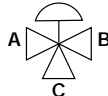

	A	B	C
Outlet Port	<input type="checkbox"/>	<input type="checkbox"/>	<input type="checkbox"/>
Close Port on Air Loss	<input type="checkbox"/>	<input type="checkbox"/>	<input type="checkbox"/>

Actuator
 Spring Action:
 Air to Open
 Air to Close
 Last Position
 Available Air Supply Pressure:
 Max. _____
 Min. _____
 Manual Override:
 Yes
 No
 Type _____

Solenoid
 Yes
 No
 Type _____
 Voltage _____

Positioner
 Yes
 No
 Type _____
 Pneu
 I/P

Switch
 Yes
 No
 Type _____

Air Set
 Yes
 No
 Type: _____
 Range: _____

Other Accessories
 Yes
 No
 Type _____

Test ANSI/FCI Leakage Class:
 IV

12 GTW 3-WAY VALVE ACTUATOR SIZING INFORMATION

Based on your valve size and service please complete the appropriate questionnaire section below. We require this information to size the smallest actuator possible for your application. We have requested the data this way because the ports may be at different pressures when one or the other port is closed. It is very important that

you advise the correct outlet pressures so the actuator is not grossly oversized. If the customer does not have any down stream pressure when the valve is closed the actuator will be extremely large as the valve becomes an unbalanced design.

1/2" through 2" Diverting Service

Upon air failure close Port A _____(direct) or Port B _____(reverse)

Valve Size _____

Type of packing _____

Shutoff Class _____

P1C - Inlet valve pressure _____

Port A closed

P2A - Outlet valve pressure on Port A _____

P2B - Outlet valve pressure on Port B _____

Port B closed

P2A - Outlet valve pressure on Port A _____

P2B - Outlet valve pressure on Port B _____

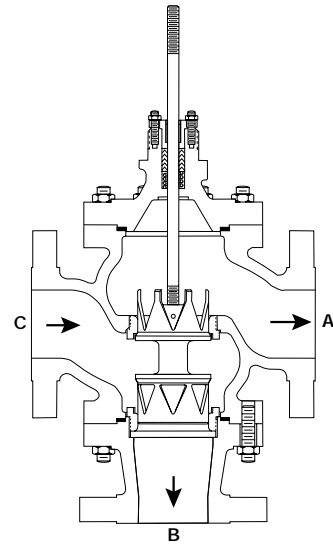

2½" through 12" Diverting Service

Upon air failure close Port A _____(direct) or Port B _____(reverse)

Valve Size _____

Type of packing _____

Shutoff Class _____

P1C - Inlet valve pressure _____

Port A closed

P2A - Outlet valve pressure on Port A _____

P2B - Outlet valve pressure on Port B _____

Port B closed

P2A - Outlet valve pressure on Port A _____

P2B - Outlet valve pressure on Port B _____

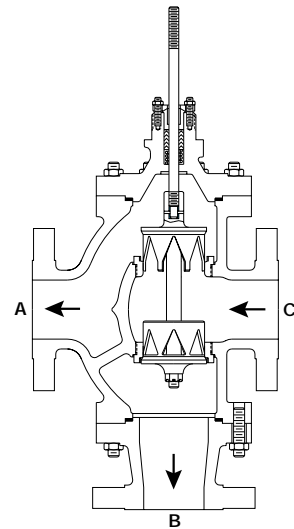

1/2" through 12" Mixing Service

Upon air failure close Port A _____(direct) or Port B _____(reverse)

Valve Size _____

Type of packing _____

Shutoff Class _____

P2C - Outlet valve pressure _____

Port A closed

P1A - Inlet valve pressure on Port A _____

P1B - Inlet valve pressure on Port B _____

Port B closed

P1A - Inlet valve pressure on Port A _____

P1B - Inlet valve pressure on Port B _____

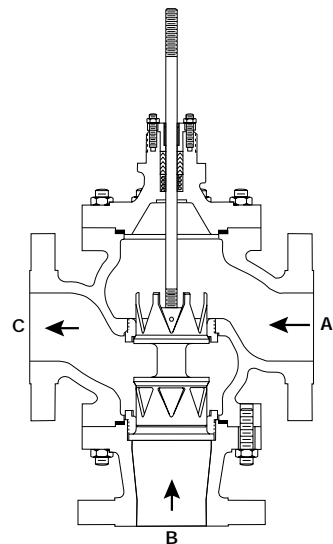

DOT 3-Way Valve Specification Form

 <p>LESLIE CONTROLS, INC. A division of CIRCOR International, Inc. 12501 Telecom Drive · Tampa, Florida 33637 (813) 978-1000 · FAX: (813)-978-0984</p> <p style="font-size: 1.2em; font-weight: bold; color: red; text-align: center;">CONTROL VALVE SPEC SHEET</p>	Project/Job _____	Data Sheet _____ of _____
	Unit/Customer _____	Spec _____
	P.O./LCO File # _____	Tag _____
	Item _____	Dwg _____
	Contract _____	Service _____
MFR Serial# _____		

Fluid <input type="checkbox"/> Steam <input type="checkbox"/> Water <input type="checkbox"/> Gas _____ <input type="checkbox"/> Liquid _____	Crit Pres PC _____
---	--------------------

Service Conditions Flow <input type="checkbox"/> #/hr <input type="checkbox"/> gpm <input type="checkbox"/> scfh <input type="checkbox"/> _____ Inlet Pressure <input type="checkbox"/> psig <input type="checkbox"/> psia <input type="checkbox"/> _____ Outlet Pressure <input type="checkbox"/> psig <input type="checkbox"/> psia <input type="checkbox"/> _____ Temperature <input type="checkbox"/> °C <input type="checkbox"/> °F _____ Max Press/Temperature: _____ / _____ Density/MW/SG _____ / _____ / _____ Viscosity _____ CP Vapor Pressure <input type="checkbox"/> psia <input type="checkbox"/> _____ Required C _v _____ Noise (dBA) Allowable _____	Max. Flow	Norm. Flow	Min. Flow	Shut-off Pressure

Line Info Pipe Size In _____ /Sch _____ Pipe Size Out _____ /Sch _____
--

Valve, Body & Bonnet Body Size in. <input type="checkbox"/> 1 <input type="checkbox"/> 1¼ <input type="checkbox"/> 1½ <input type="checkbox"/> 2 <input type="checkbox"/> 2½ <input type="checkbox"/> 3 ANSI Class <input type="checkbox"/> 125 <input type="checkbox"/> 150 <input type="checkbox"/> Other _____ Body/Bonnet Material: <input type="checkbox"/> Cast Iron <input type="checkbox"/> Bronze End Conn. Inlet/Outlet: <input type="checkbox"/> Threaded <input type="checkbox"/> Int. Flange <input type="checkbox"/> Other _____ Packing Material: <input type="checkbox"/> Teflon Chevron <input type="checkbox"/> *Special EPDM Seals for 450°F

Trim Size <input type="checkbox"/> 100% - Quick Opening <input type="checkbox"/> SST <input type="checkbox"/> Monel

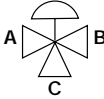
Flow Path <input type="checkbox"/> Mixing (Converging) (choose one outlet port) <input type="checkbox"/> Diverting (Diverging) (choose two outlet ports)		<table border="1" style="width: 100%; border-collapse: collapse;"> <tr> <td style="width: 60%;"></td> <td style="width: 10%; text-align: center;">A</td> <td style="width: 10%; text-align: center;">B</td> <td style="width: 10%; text-align: center;">C</td> </tr> <tr> <td>Outlet Port</td> <td style="text-align: center;"><input type="checkbox"/></td> <td style="text-align: center;"><input type="checkbox"/></td> <td style="text-align: center;"><input type="checkbox"/></td> </tr> <tr> <td>Close Port on Air Loss</td> <td style="text-align: center;"><input type="checkbox"/></td> <td style="text-align: center;"><input type="checkbox"/></td> <td style="text-align: center;"><input type="checkbox"/></td> </tr> </table>		A	B	C	Outlet Port	<input type="checkbox"/>	<input type="checkbox"/>	<input type="checkbox"/>	Close Port on Air Loss	<input type="checkbox"/>	<input type="checkbox"/>	<input type="checkbox"/>
	A	B	C											
Outlet Port	<input type="checkbox"/>	<input type="checkbox"/>	<input type="checkbox"/>											
Close Port on Air Loss	<input type="checkbox"/>	<input type="checkbox"/>	<input type="checkbox"/>											

Actuator <input type="checkbox"/> 35 <input type="checkbox"/> 55 <input type="checkbox"/> 85 <input type="checkbox"/> Converging <input type="checkbox"/> Diverting <input type="checkbox"/> None Available Air Supply Pressure: Max. _____ Min. _____ Manual Override: <input type="checkbox"/> Yes <input type="checkbox"/> No <input type="checkbox"/> Type _____
--

Solenoid <input type="checkbox"/> Yes <input type="checkbox"/> No <input type="checkbox"/> Type _____ <input type="checkbox"/> Voltage _____

Positioner <input type="checkbox"/> Yes <input type="checkbox"/> No <input type="checkbox"/> Type _____ <input type="checkbox"/> Pneu <input type="checkbox"/> I/P

Switch <input type="checkbox"/> Yes <input type="checkbox"/> No <input type="checkbox"/> Type _____
--

Air Set <input type="checkbox"/> Yes <input type="checkbox"/> No <input type="checkbox"/> Type: _____ <input type="checkbox"/> Range: _____
--

Other Accessories <input type="checkbox"/> Yes <input type="checkbox"/> No <input type="checkbox"/> Type _____

Test ANSI/FCI Leakage Class: <input type="checkbox"/> .1% of capacity (std)
--

DOT ORDER CODE

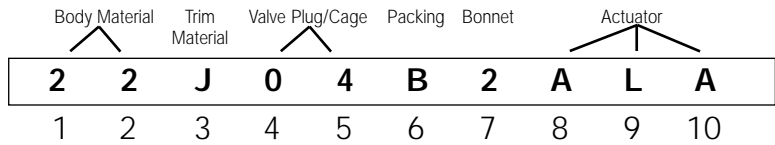

<p>Body Material - Position 1 & 2</p> <p>02 = Cast Iron</p> <p>22 = Bronze</p>
<p>Trim Material - Position 3</p> <p>A = Stainless Steel, Renewable Seat</p> <p>J = Monel</p>
<p>Valve Plug/Cage - Position 4 & 5</p> <p>04 = Quick Opening - Q.O.</p>
<p>Packing - Position 6</p> <p>B = Teflon Chevron</p>

<p>Bonnet - Position 7</p> <p>2 = Regular (up to 450°F)</p>
<p>Actuator - Position 8, 9 & 10</p> <p>U = 35 Iron</p> <p>Y = 35R Iron</p> <p>AL = 55 Iron</p> <p>ALA = 55A Iron</p> <p>GLA = 55AR Iron</p> <p>GL = 55R Iron</p> <p>BL = 85 Iron</p> <p>HL = 85R Iron</p>

VALVE AVAILABILITY CHART

Body Material	ANSI Class	Size		Actuator Standard	Threaded Ends	Flanged Ends	
		Inches	mm			ANSI	DIN
CAST IRON	125	1	25	35(R)	X	Class 125 All Sizes	ND-10 ND-16 All Sizes
		1¼	32	35(R)	X		
		1½	40	35(R)	X		
		2	50	35(R)	X		
		2½	65	55A(R)	—		
		3	80	55A(R)	—		
BRONZE	150	1	25	35(R)	—	Class 150 All Sizes	ND-10 ND-16 All Sizes
		1¼	32	35(R)	—		
		1½	40	35(R)	—		
		2	50	35(R)	—		
		2½	65	55A(R)	—		
		3	80	55A(R)	—		

BY-PASS TEMPERATURE CONTROL

By-pass temperature control describes a simple method for controlling the temperature of one fluid with another fluid. A typical system consists basically of a heat source, a cooler, connecting fluid direction: the DOT 3-Way Control Valve.

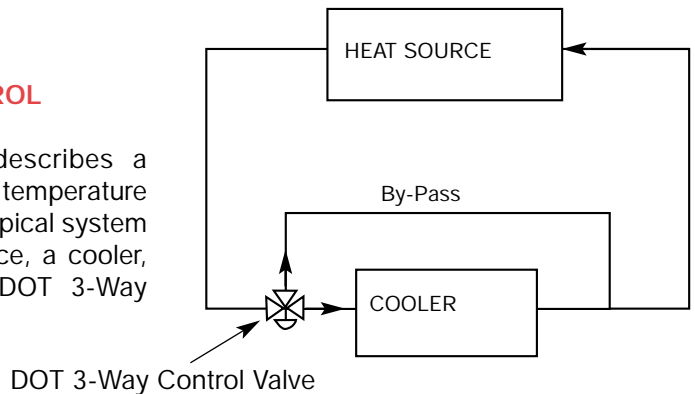

RVK 3-Way Valve Specification Form

 LESLIE CONTROLS, INC. <small>A division of CIRCOR International, Inc. 12501 Telecom Drive · Tampa, Florida 33637 (813) 978-1000 · FAX: (813)-978-0984</small>	Project/Job _____	Data Sheet _____ of _____
	Unit/Customer _____	Spec _____
	P.O./LCO File # _____	Tag _____
	Item _____	Dwg _____
	Contract _____	Service _____
	MFR Serial# _____	

Fluid Steam Water Gas _____ Liquid _____ Crit Pres PC _____

<p>Service Conditions</p> <p>Flow <input type="checkbox"/> #/hr <input type="checkbox"/> gpm <input type="checkbox"/> scfh <input type="checkbox"/> _____</p> <p>Inlet Pressure <input type="checkbox"/> psig <input type="checkbox"/> psia <input type="checkbox"/> _____</p> <p>Outlet Pressure <input type="checkbox"/> psig <input type="checkbox"/> psia <input type="checkbox"/> _____</p> <p>Temperature <input type="checkbox"/> °C <input type="checkbox"/> °F _____</p> <p>Max Press/Temperature: _____ / _____</p> <p>Density/MW/SG _____ / _____ / _____</p> <p>Viscosity _____ CP</p> <p>Vapor Pressure <input type="checkbox"/> psia <input type="checkbox"/> _____</p> <p>Required C_v _____ Noise (dBA) Allowable _____</p>	Max. Flow	Norm. Flow	Min. Flow	Shut-off Pressure

Line Info Pipe Size In _____ /Sch _____ Pipe Size Out _____ /Sch _____

Valve, Body & Bonnet

Body Size in. 4 6 8 10 12 16

ANSI Class 125 150 ND Other _____

Body/Bonnet Material: Cast Iron Bronze Ductile Iron Other _____

End Conn. Inlet/Outlet: Int. Flange Other _____

Packing Material: O-Ring Buna-N Other _____

Trim Size 100% Reduced (Rotary 3-Way only)

Flow Path

Mixing (Converging) (choose one outlet port)

Diverting (Diverging) (choose two outlet ports)

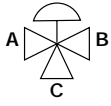

	A	B	C
Outlet Port	<input type="checkbox"/>	<input type="checkbox"/>	<input type="checkbox"/>
Close Port on Air Loss	<input type="checkbox"/>	<input type="checkbox"/>	<input type="checkbox"/>

Actuator

55 85 Converging Diverging None

Available Air Supply Pressure: Max. _____ Min. _____

Manual Override: Yes No Type _____

Solenoid Yes No Type _____ Voltage _____

Positioner Yes No Type _____ Pneu I/P

Switch Yes No Type _____

Air Set Yes No Type: _____ Range: _____

Other Accessories Yes No Type _____

Test ANSI/FCI Leakage Class: 1.5% of Capacity for Diverging 1.8% of Capacity for Converging

DIGI ACTUATOR ORDER CODE

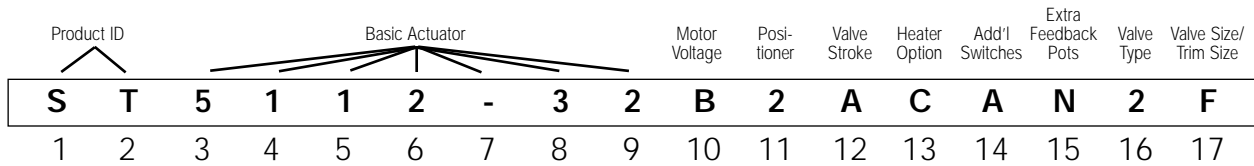

Product ID - Position 1 & 2 ST = Digi Actuator
Basic Actuator - Position 3-9 5112-32 = 100 Sec/in 1 Phaze 24V, 115V (120V), 230V 50/60 Hz AC, 24V DC
5112-33 = 50 Sec/in 1 Phaze 24V, 115V (120V), 230V 50/60 Hz AC, 24V DC
5112-34 = 25 Sec/in 1 Phaze 24V, 115V (120V), 230V 50/60 Hz AC, 24V DC
5113-06 = 15 Sec/in 3 Phaze 400V, 50/60 Hz AC
5113-07 = 15 Sec/in 1 Phaze 115 & 230V, 50/60 Hz AC
5113-14 = 29 Sec/in 3 Phaze 400V, 50/60 Hz AC
5113-34 = 58 Sec/in 3 Phaze 400V, 50/60 Hz AC
5113-51 = 181 Sec/in 1 Phaze 24V, 115V, 230V, 50/60 Hz AC, 24V DC
5113-15 = 29 Sec/in 1 Phaze 24V, 115V, 230V, 50/60 Hz AC, 24V DC
5113-35 = 58 Sec/in 1 Phaze 24V, 115V, 230V, 50/60 Hz AC, 24V DC

5113-53 = 97 Sec/in 1 Phaze 24V, 115V, 230V, 50/60 Hz AC, 24V DC
5114-17 = 29 Sec/in 1 Phaze 24V, 115V, 230V, 50/60 Hz AC
5114-36 = 58 Sec/in 3 Phaze 400V, 50/60 Hz AC
5114-54 = 97 Sec/in 3 Phaze 400V, 50/60 Hz AC
5114-37 = 58 Sec/in 1 Phaze 24V, 115V, 230V, 50/60 Hz AC, 24V DC
5114-55 = 97 Sec/in 1 Phaze 24V, 115V, 230V, 50/60 Hz AC, 24V DC
5114-06 = 15.38 Sec/in 3 Phaze 400V, 50/60 Hz AC
XXXX-XX = Other
Motor Voltage - Position 10 A = 24 VDC B = 115 VAC C = 230 VAC E = 24 VAC F = 400 VAC X = Other
Positioner - Position 11 N = None 1 = RE3446 (4-20mA) Analog type 2 = RE3446 (0-10 VDC) Analog type X = Other

Valve Stroke - Position 12 A = .75" to 1" B = 1.25" C = 1.5" D = 2" to 3" X = Other
Heater Option - Position 13 N = None A = 24 VDC (E68717) B = 115 VAC (E68718) C = 230 VAC (E68719) X = Other
Add'l Switches ¹ - Position 14 N = None A = 250 Volt 10 Amp (Qty 2) (E68720) X = Other
Extra Feedback Pots - Position 15 N = None 1 = 1000 Ohm X = Other
Valve Type - Position 16 N = None 1 = DLO 2 = DBOY 3 = GTW X = Other
Valve Size (DBOY) Valve Trim (DLO) - Position 17 N = None A = .5" B = .75" C = 1" D = 1.5" E = 2" F = 2.5" G = 3" H = 4" J = 6" K = 8" X = Other

1. One set included with actuator.

2500 SERIES Valve Specification Form

Laurence Products, Electric On / Off

 <p style="font-size: small;">A division of CIRCOR International, Inc. 12501 Telecom Drive · Tampa, Florida 33637 (813) 978-1000 · FAX: (813)-978-0984</p> <p style="color: red; font-weight: bold; font-size: large;">CONTROL VALVE SPEC SHEET</p>	Project/Job _____	Data Sheet _____ of _____
	Unit/Customer _____	Spec _____
	P.O./LCO File # _____	Tag _____
	Item _____	Dwg _____
	Contract _____	Service _____
MFR Serial# _____		

I have (or anticipate) a requirement for an electrically actuated valve as follows:

Quantity _____ Pipe Size _____

- 2-way
 - Fully Electrical
 - Energize to Open (Normally Closed)
 - Energize to close (Normally Open)
 - Manually Reset
 - Latch to Open (Normally Closed)
 - Latch to Close (Normally Open)
- Trip on Current Failure Free Handle Trip on Energization

- 3-way
 - Fully Electrical
 - Manually Reset
 - Trip on Current Failure Free Handle
 - Trip on Energization
 - Pilot Control
 - Supply Normally Closed (when de-energized or unlatched)
 - Supply Normally Open
 - Directional
 - Diverting - 1 inlet, 2 outlets
 - Selecting - 2 inlets, 1 outlet

**See
Flow Forms
On Back**

- 4-way
 - Fully Electrical
 - Manually Reset
 - Trip on Current Failure Free Handle
 - Trip on Energization

Summary of Application _____

Fluid Handled _____ Viscosity _____ @ _____ Clean? _____ Conc. _____ Spec. Grav. _____

Max Opening Differential Pressure _____ Fluid Temp _____ Ambient Temp _____

Flow Rate _____ Max Allowable Pressure Drop _____ Req'd C_v _____

Body Mat'l _____ Inner Parts _____ Valve Disc _____

Screwed Ends Flanged 150 Flanged 300 Socketweld Buttweld Other _____

Horizontal Pipe Mounting Vertical Pipe Mounting- Up Flow Down Flow

Actuator Enclosure: NEMA4 Watertight/Dusttight Explosion Proof Class I,

Group _____ Div _____

Other _____

AC DC Volts _____ Hz _____ Duty _____ Frequency of Operation _____

Coil Insulation Class H (std) Other _____ Position Switch(es) _____

Other Options _____

Other Description _____

Please send _____ copies of dimension drawing _____ copies of Laurence On-Off Valves Handbook.

ELECTRIC ON-OFF SERIES VALVES

3-WAY FLOW FORMS

Each 3-way valve is factory adjusted for one of the following Flow Forms:

For Pilot Control:

Form M - Supply normally closed
Energize to open inlet port.
De-energize to vent.

Form N - Supply normally open
Energize to vent.
De-energize to open inlet port.

For Directional Control:

Form O - Diverting (one inlet, two outlets)
Energize to open normally closed outlet & close normally open outlet.
De-energize to reverse above action (return to normal position).

Form P - Selecting (two inlets, one outlet)
Energize to open normally closed inlet & close normally open inlet.
De-energize to reverse above action (return to normal position).

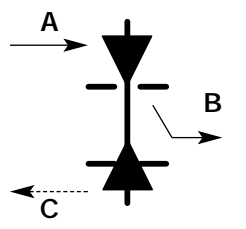
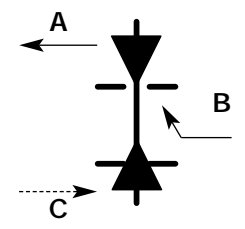
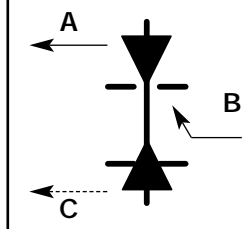
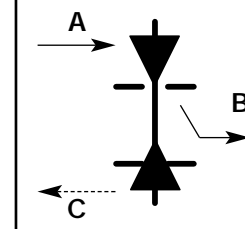
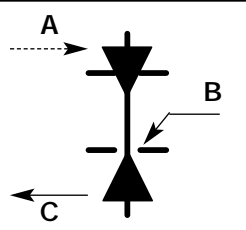
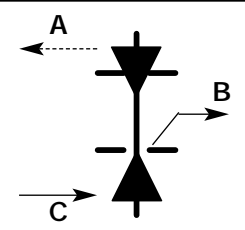
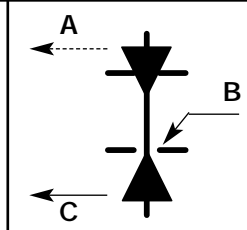
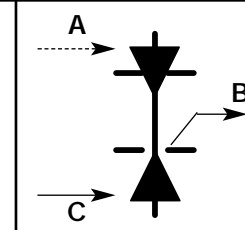
	FLOW FORM M INLET AT A OUTLET AT B VENT AT C	FLOW FORM N INLET AT C OUTLET AT B VENT AT A	FLOW FORM O INLET AT B OUTLETS AT A & C	FLOW FORM P INLETS AT A & C OUTLETS AT A & C
ACTUATED POSITION (SOLENOID ENERGIZED)				
NORMAL POSITION (SOLENOID DE-ENERGIZED)				

2800 Series Fire-Cide® Valve Specification Form

Laurence Product, Fusible Link

 <p>LESLIE CONTROLS, INC. A division of CIRCOR International, Inc. 12501 Telecom Drive · Tampa, Florida 33637 (813) 978-1000 · FAX: (813)-978-0984</p> <p>CONTROL VALVE SPEC SHEET</p>	Project/Job _____	Data Sheet _____ of _____
	Unit/Customer _____	Spec _____
	P.O./LCO File # _____	Tag _____
	Item _____	Dwg _____
	Contract _____	Service _____
	MFR Serial# _____	

I have (or anticipate) a requirement for a Fire Safety Shut Off valve as follows:

Quantity _____ Pipe Size _____ FM Approved

2-way Fail Closed
 Fail Open

Summary of Application _____

Fluid Handled _____ Spec. Grav. _____

Viscosity _____ Concentration _____ Free of Solids? _____

Max Inlet Pressure _____ Min/Max Fluid Temp _____

Flow Rate _____ Max Allowable Pressure Drop _____

Temperature Rating of Fusible Link Desired _____

Body Mat'l _____ Inner Parts _____ Valve Disc _____

Screwed Ends Flanged 150 Flanged 300 Other _____

Horizontal Pipe Mounting Vertical Pipe Mounting- Up Flow Down Flow

Position Switch to Indicate- Valve Open Valve Closed SPDT DPDT

Other Description _____

Please send _____ copies of an applicable dimension drawing.

Please send _____ additional copies of Laurence On-Off Valves Handbook.

ELECTRIC ON/OFF ACTUATORS Specification Form

From R.G. Laurence Product Line

 <p style="font-size: small;">A division of CIRCOR International, Inc. 12501 Telecom Drive · Tampa, Florida 33637 (813) 978-1000 · FAX: (813)-978-0984</p> <p style="text-align: center; color: red; font-weight: bold; font-size: 1.2em;">CONTROL VALVE SPEC SHEET</p>	Project/Job _____ Unit/Customer _____ P.O./LCO File # _____ Item _____ Contract _____ MFR Serial# _____	Data Sheet _____ of _____ Spec _____ Tag _____ Dwg _____ Service _____
--	--	--

I have (or anticipate) a requirement for an actuator as follows:

Quantity _____ A.C. D.C. Voltage _____ Hertz _____

Summary of Application _____

Actuator Enclosure: NEMA4 Watertight/Dusttight Explosion Proof Class I, Group _____ Div _____
 Other _____

Solenoid: Your net pull or push force (load) in lbs. _____ Plunger travel (stroke) required in inches _____
 PLEASE SUBMIT DESCRIPTION OR GRAPH OF LOAD VS. STROKE

Solenoid Actuator to be mounted with axis: Horizontal Vertical
 Pulling Up Pulling Down Pushing Up Pushing Down

Will you provide a spring return for the Solenoid Actuator? _____
 IF SO, SUBMIT DESCRIPTION OR GRAPH OF SPRING TENSION (OR COMPRESSION) VS. STROKE

Type of plunger connection Clevis w/Hole Threaded Rod Threaded Hole _____

Electromagnetic: Your net holding force (load) in lbs. _____
 Pole piece design, if other than standard _____

Maximum Period of Energization _____ Frequency of Operation _____

Ambient Temperature Range _____ Indoors/Outdoors _____

Coil insulation Class H (std) Molded Other _____

Special Electrical Characteristics _____

Mounting description or provisions required _____

Are there any weight, dimensional or shape limitations? _____

Coil to have Lead Wires (std) Terminal Block Other _____

Conduit connection 1/2" NPT (std) 3/4" NPT Other _____

Other Description _____

Please send _____ copies of dimension drawing _____ copies of Laurence On-Off Valves Handbook.

Specification Form for Measurement and Control Instruments, Primary Elements and Control Valves

 <p>LESLIE CONTROLS, INC. A division of CIRCOR International, Inc. 12501 Telecom Drive · Tampa, Florida 33637 (813) 978-1000 · FAX: (813)-978-0984</p>		CUSTOMER				DATA SHEET			
		PROJECT				SPEC			
		SITE/UNIT				TAG			
		QUOTE/P.O.				DWG			
		ITEM				SERVICE			
		CONTRACT							
1	Fluid					Crit Press Pc			
2	SERVICE CONDITIONS		Units	Cond 1	Cond 2	Cond 3	Cond 4	Shut-Off	
3		Flow Rate						---	
4		Inlet Pressure							
5		Outlet Pressure							
6		Inlet Temperature							
7		Spec Wt / Spec Grav / Mol Wt							
8		Viscosity / Spec Heats Ratio							
9		Vapor Pressure Pv							
10		Required Cv							
11		% Travel							
12		Allowable / Predicted SPL	dBA						
13			SPL After Noise Attenuation	dBA					
14	LINE	Pipe Line Size	In					53	Type
15		& Schedule	Out					54	Mfr. & Model
16		Pipe Line Insulation					55	Size	
17	VALVE BODY / BONNET	Type					56	On/Off	
18		Size					57	Spring Action on Open/Close	
19		Max Press/Temp					58	Max Allowable Pressure	
20		Mfr. & Model					59	Min Required Pressure	
21		Body/Bonnet Matl					60	Available Air Supply Pressure:	
22		Liner Material/ID					61	Max Min	
23		End In					62	Spring - Bench Range	
24		Connection Out					63	Actuator Orientation	
25		Flg Face Finish					64	Handwheel Type	
26		End Ext/Matl					65	Air Failure Valve	
27		Flow Direction					66	Solenoid Qty	
28		Type of Bonnet					67	Input Signal	
29	Lube & Iso Valve	Lube					68	Type	
30	Packing Material					69	Mfr. & Model		
31	Packing Type					70	On Incr Signal Output Incr/Decr		
32	TRIM	Type					71	Gauges Bypass	
33		Size	Rated Travel				72	Cam Characteristic	
34		Characteristic					73		
35		Balanced/Unbalanced					74	Type Quantity	
36		Rated Cv	Fl	Xt			75	Mfr. & Model	
37		Plug/Ball/Disk Material					76	Contacts/Rating	
38		Seat Material					77	Actuation Points	
39		Cage/Guide Material					78		
40	Stem Material					79	Mfr. & Model		
41						80	Set Pressure		
42						81	Filter Gauge		
43						82			
44	SPECIALS/ACCESSORIES	NEC Class	Group	Div			83		
45							84	Hydro Pressure	
46							85	ANSI/FCI Leakage Class	
47							86	Calculated Stem Thrust	
48							Rev	Date	
49							Revision		
50						Orig	App		
51									
52									

LESLIE MODEL QT

Steam Conditioning System Specification Form

 <p>LESLIE CONTROLS, INC. A division of CIRCOR International, Inc. 12501 Telecom Drive · Tampa, Florida 33637 (813) 978-1000 · FAX: (813)-978-0984</p> <p style="color: red; font-weight: bold; font-size: 1.2em;">CONTROL VALVE SPEC SHEET</p>	Project/Job _____	Data Sheet _____ of _____
	Unit/Customer _____	Spec _____
	P.O./LCO File # _____	Tag _____
	Item _____	Dwg _____
	Contract _____	Service _____
MFR Serial# _____		

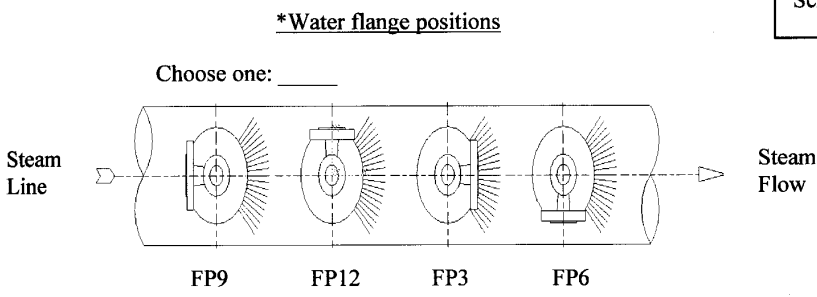
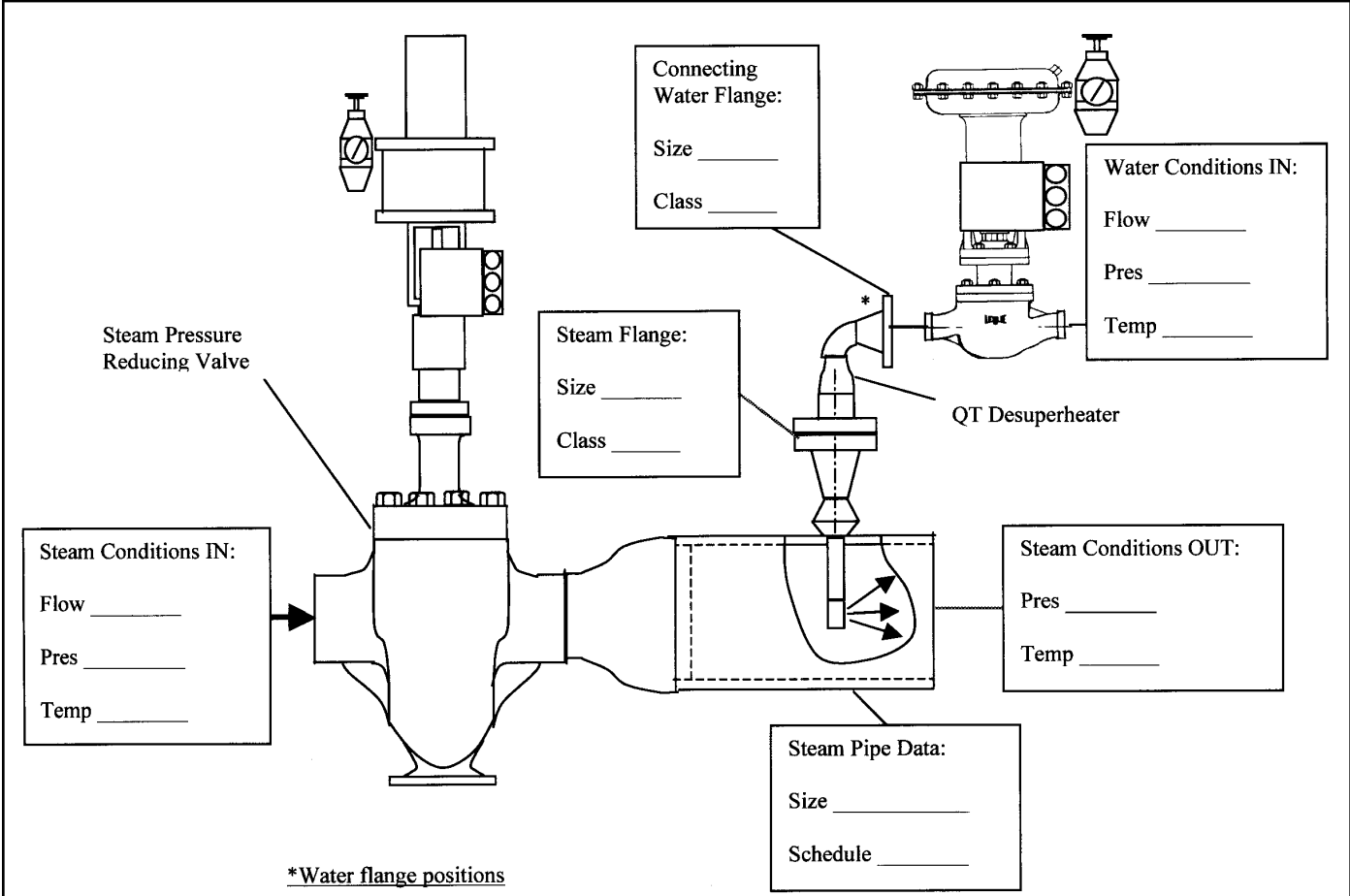

Note: Spraywater must be injected in the direction of the steam flow. Select appropriate spray head position.

Distance to Sensor: distance from injection point to temp sensor should be 40-50 ft. Systems operating at pressures above 362psi can have significantly less run to the sensor (consult factory).

Required Straight Pipe Run: distance from injection point to first pipe bend is also a function of steam pressure, temp and nozzle size. Based on experience systems up to 362psi, 13-20ft, is an acceptable distance.

Turndown ratio: normally 4:1 on the water flow control. Ratio is determined by dividing "steam flow max" x "steam flow min".

LESLIE MODEL AT

Steam Conditioning System Specification Form

 LESLIE CONTROLS, INC. <small>A division of CIRCOR International, Inc.</small> <small>12501 Telecom Drive · Tampa, Florida 33637</small> <small>(813) 978-1000 · FAX: (813)-978-0984</small> CONTROL VALVE SPEC SHEET	Project/Job _____	Data Sheet _____ of _____
	Unit/Customer _____	Spec _____
	P.O./LCO File # _____	Tag _____
	Item _____	Dwg _____
	Contract _____	Service _____
MFR Serial# _____		

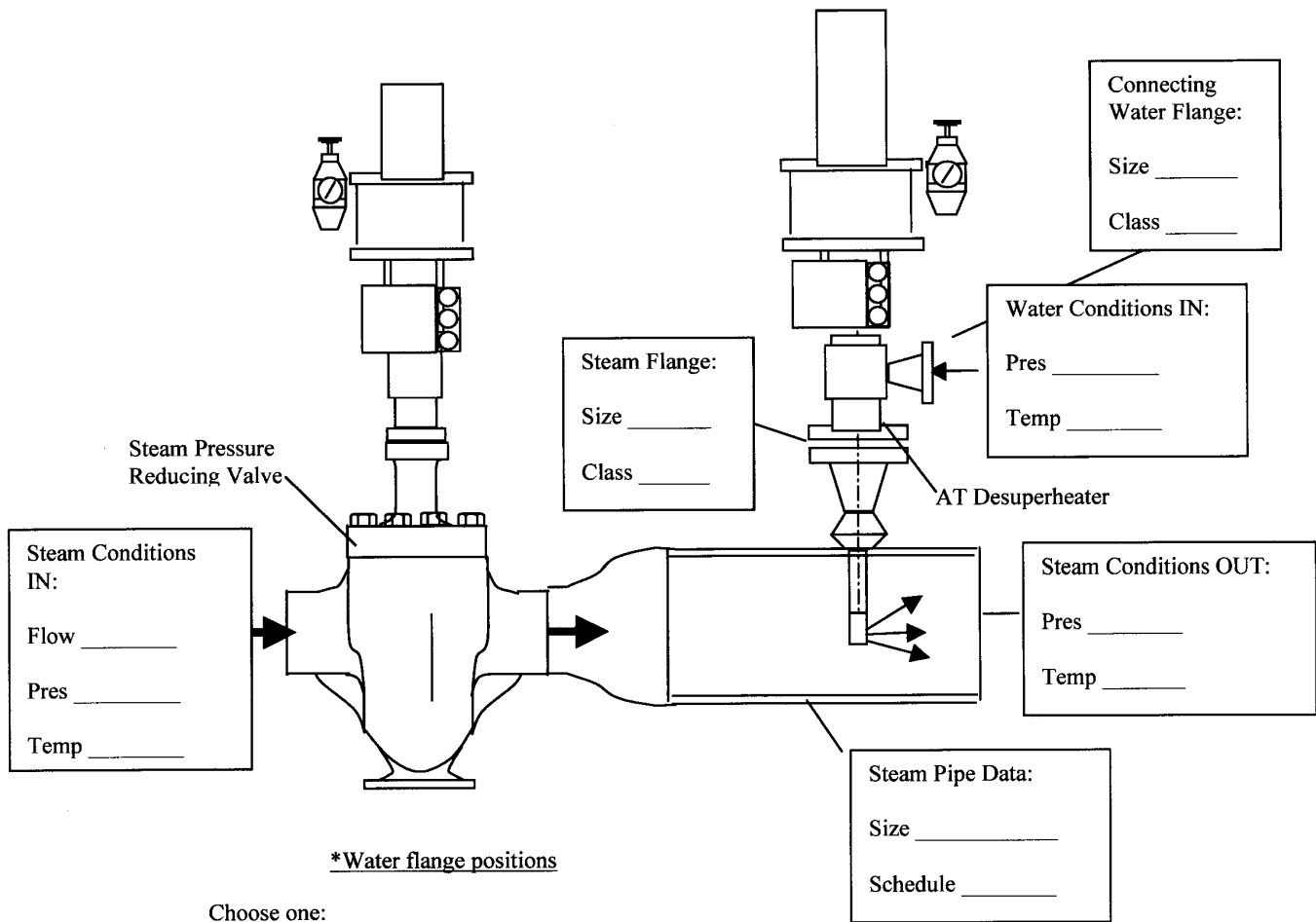

***Water flange positions**

Choose one: _____

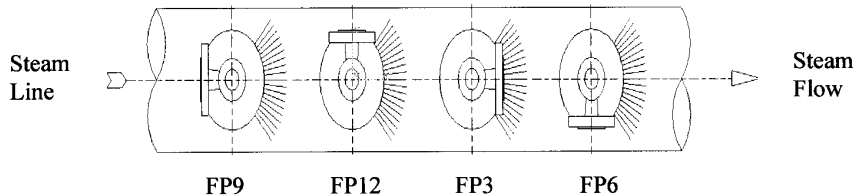

Note: Spraywater must be injected in the direction of the steam flow. Select appropriate spray head flange position.

Use on medium/low pressure steam applications. There is no water control valve. The AT desuperheater valve regulates the amount of injection water by varying the number of injection nozzles. This enables the water pressure to remain constant, independent of the number of injection nozzles in operation.

Distance to Sensor: distance from injection point to temp sensor should be 40-50 ft. Systems operating at pressures above 362psi can have significantly less run to the sensor (consult factory).

Required Straight Pipe Run: distance from injection point to first pipe bend is also a function of steam pressure, temp and nozzle size. Based on experience systems up to 362psi, 13-20ft, is an acceptable distance.

Turndown ratio: normally 18:1 and 27:1. Ratio is determined by dividing "steam flow max" x "steam flow min".

LESLIE MODEL SPID

Desuperheater Specification Form

 LESLIE CONTROLS, INC. <small>A division of CIRCOR International, Inc. 12501 Telecom Drive · Tampa, Florida 33637 (813) 978-1000 · FAX: (813)-978-0984</small> CONTROL VALVE SPEC SHEET	Project/Job _____	Data Sheet _____ of _____
	Unit/Customer _____	Spec _____
	P.O./LCO File # _____	Tag _____
	Item _____	Dwg _____
	Contract _____	Service _____
	MFR Serial# _____	

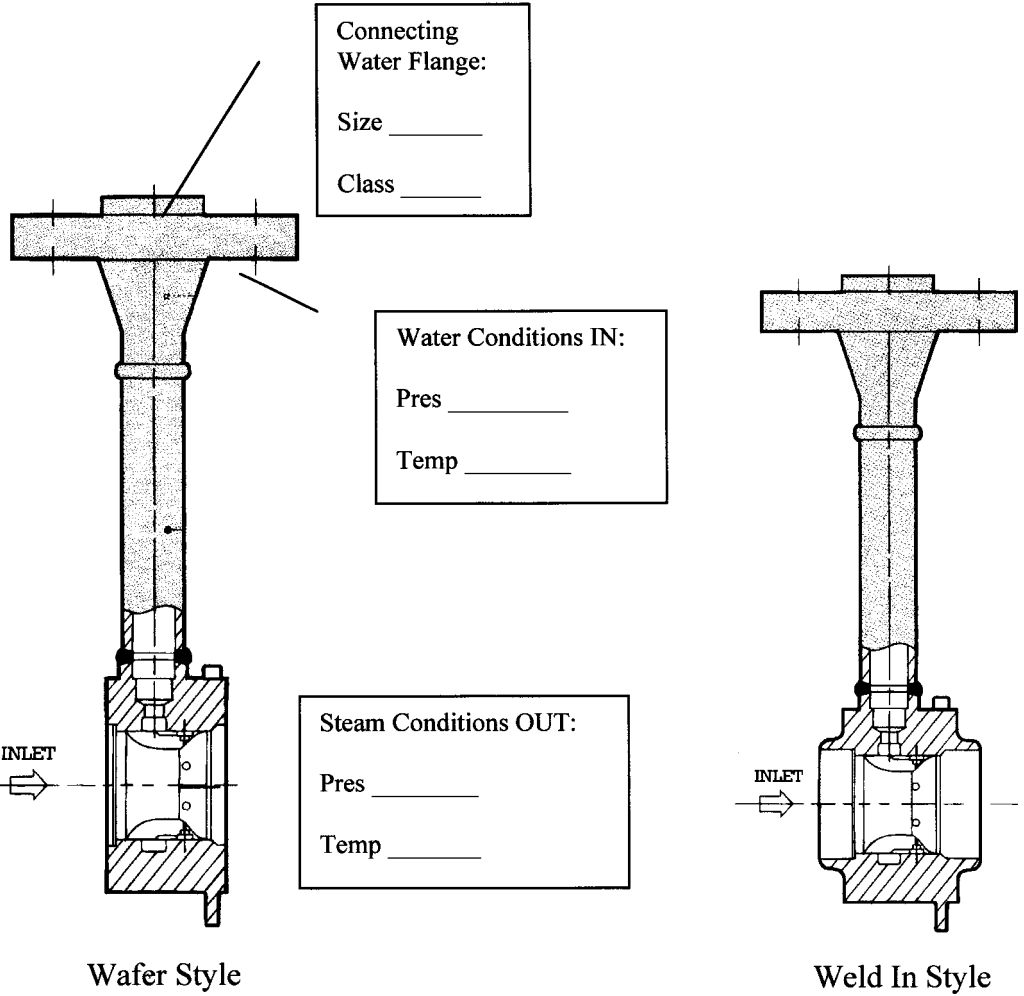

For use in small steam lines with minimal steam pressure losses. Steam control within 43°F of saturation temp and +/- 1% of controller range. Water flange connection available 1/2" - 1" size. Steam connection available in wafer or butt weld in 1 1/2" - 4" size.

Distance to Sensor: distance from injection point to temp sensor should be 40-50 ft. Systems operating at pressures above 362psi can have significantly less run to the sensor (consult factory).

Required Straight Pipe Run: upstream straight pipe run is normally 6xD and the downstream straight pipe run 20xD, as a minimum. For other distance applications consult factory.

Turndown ratio: normally 1:40. Ratio is determined by dividing "steam flow max" x "steam flow min".